

在使用缝纫机之前请阅读本使用说明书。
请将本使用说明书放在便于查阅的地方保管。



步进三自动罗拉车一体机 ZJ8650/ZJ8660系列
AUTOMATIC STEP MOTOR FEED POST BED SEWING
MACHINE SERIES

使用说明书 OPERATION MANUAL 零件手册 PARTS BOOK



手机官网



官方订阅号

浙江中捷缝纫科技有限公司
ZOJE SEWING MACHINE CO.,LTD

为了创造更加美好的环境

请您协作

首先对您使用本公司的产品表示衷心的感谢！

本公司致力于关爱地球环境，制定了“智能制造、绿色制造”的基本方针。当地的公民在环境保护活动中也应该对当地社会、环境二方面尽每个人的微薄之力。

因此，希望您能配合这个计划，作为环境保护活动的一环，在平时处理废弃物的时候能多加注意。

1. 不用的包 材料 ， 为了能再次回收利用， 请交付给当地相关回收公司进行处理。
2. 使用完的润滑油、请根 相关的 律 和规定进行妥善处理。
3. 产品保养或修理需要更换零部件时， 有不需要的电路板和电子零件， 以及产品废弃时， 请作为电子废弃物处理。

In order to create a better environment

Please cooperate with you

First of all, I would like to express my heartfelt thanks to you for using our products.

Our company is committed to caring for the earth's environment and has formulated the basic policy of "intelligent manufacturing and green manufacturing". Local citizens in environmental protection activities should also do little to the local community, the environment two aspects of everyone's contribution.

Therefore, I hope you can cooperate with this plan, as part of the environmental protection activities, when dealing with wastes in peacetime can pay more attention.

1. Unused packaging materials, in order to be recycled again, please send them to the local recycling company for disposal.
2. Lubricants used shall be properly handled according to relevant laws and regulations.
3. When parts need to be replaced in product maintenance or repair, there are unnecessary circuit boards and electronic parts, and when products are discarded, please treat them as electronic waste.

非常感谢您购买本公司的工业缝纫机

在使用缝纫机之前，请仔细阅读<为了您的安全使用>和使用说明。

工业缝纫机的特性之一，因为要在机针和旋梭等运动零部件附近进行操作，而这些零部件很容易引起受伤的危险，所以请在受过培训的人或熟练人员的安全操作知识的指导下，正确地使用本缝纫机。



为了您的安全使用

[1] 安全使用的标记及其意义

本使用说明书及产品所使用的标记和图案记号是为了您的安全而正确地使用产品，防止您及其他人受到危害和损害。

表示方 及含意如下。

标记

 危险	该内容表示如果忽视此标记而进行了错误的操作，必将导致死亡或重伤。
 警告	该内容表示如果忽视此标记而进行了错误的操作，肯定会引起人员死亡或重伤。
 注意	如果忽视此标记而进行错误的操作，有可能会引起人员受到轻微或中度的伤害。

图案和符号



..... 该符号(△)表示“应注意事项”。
三角中的图案表示必须要注意的实质内容。
(例如，左边的图案表示“当心受伤”。)



..... 该符号(⊘)表示“禁止”。



..... 该符号(●)表示“必须”。
圆圈中的图案表示必须要做的事情的实质内容。
(例如，左边的图案表示“必须接地”。)

Thank you very much for purchasing our industrial sewing machine
 Before using the sewing machine, please read <for your safe use> and use instructions carefully

The characteristic of industrial sewing machine is that it should be operated near the moving parts such as needles and spindles, which are easy to cause injury, so please use the sewing machine correctly under the guidance of the safety operation knowledge of trained or skilled personnel.



For Your Safe Use

[1] Safety Usage Marking And Its Significance

The labels and pattern marks used in this instructions and products are for your safety and correct use of the products to prevent you and others from being harmed and damaged.

The methods and implications are as follows.

Sign

	Danger	This content indicates that if this mark is mishandled, it will cause death to become serious.
	Warning	This content indicates that if this mark is mishandled, people will die or be seriously injured.
	Note	That if this mark is mishandled, it may cause minor or moderate injuries.

Patterns And Symbols



..... The symbol (△) indicates “points for attention”.
 The pattern in the triangle represents the essential content that must be paid attention to.
 (For example, the pattern on the left shows “watch out for injuries”.)



..... The symbol (⊘) indicates “prohibition”.



..... The symbol (●) indicates “must”.
 The pattern in the circle indicates the substance of what must be done.
 (For example, the pattern on the left shows “must be grounded”.)

[2] 安全注意事项

⚠ 危险



在关闭电源开关并将电源插头从插座上拔下后, 至少等待5分钟, 再打开控制箱盖。触摸带有高电压的区域将会造成人员伤亡。

⚠ 警告



缝纫机内不允许进入任何液体, 否则会引起火灾、电击或操作故障。

如果缝纫机内(机头或控制箱)进入任何液体, 请立即关闭电源, 并将电源插头从插座上拔出, 然后联系销售商或资深技术人员。



⚠ 注意

使用环境

请不要在有电源线干扰及静电干扰等有强电气干扰源影响的环境下使用。

强电气干扰源可能会影响缝纫机的正确操作。

电源电压的波动应该在额定电压的±10%以内的环境下使用。

电压大幅度的波动会影响缝纫机的正确操作。

电源容量应大于缝纫机的消耗电量。电源容量不足会影响缝纫机的正确操作。

环境温度应在5°C-35°C 的范围内使用。

低温或高温会影响缝纫机的正确操作。

相对湿度应在45%-85%的范围内, 并且设备内不会形成结露的环境下使用。干燥或多湿的环境和结露会影响缝纫机的正确操作。

万一发生雷电暴风雨时, 关闭电源开关, 并将电源插头从插座上拔下。雷电可能会影响缝纫机的正确操作。



请勿将USB存储器以外的设备连接到USB连接端口上。否则有可能导致故障。

安 装



请让受过培训的技术人员来安 缝纫机。

请委托购买商店或电气专业人员进行电气配线。

缝纫机重约38kg, 安 工作必须由两人以上来完成。



在安 完成前, 请不要连接电源, 如果误踩下脚踏板时, 缝纫机动作会导致受伤。

请在切断电源后, 再拔掉电插头。
不然易成为控制箱发生故障的原因。



必须接地。

接驳地线不牢固, 是造成触电或误动作的原因。

固定电缆时, 不要过度弯曲电缆或用卡钉固定得过紧, 会引起火灾或触电的危险。



如果使用带小脚轮的工作台, 则应该固定小脚轮, 使其不能移动。



缝纫机头倒下时, 请一定要固定工作台, 不可使其随意移动。

工作台移动易发生脚等被夹住之事故, 是导致人身事故的原因。



缝纫机头倒下或竖起时, 请用双手进行操作。
单手操作时因缝纫机的重量万一滑落易导致受伤。



使用润滑油和黄油时, 务必戴好保护眼镜和保护手套等, 以防润滑油落入眼中或沾在皮肤上, 这是引起发炎的原因。

另外, 润滑油或黄油不能饮用, 否则会引起呕吐和腹泻。

将油放在小孩拿不到的地方。

[2] Safety Precautions

Danger



After closing the power switch and unplugging the power plug from the socket, wait for at least 5 minutes before opening the control box cover. Touching areas with high voltage can cause casualties.

Warning



No liquid is allowed to enter the sewing machine, otherwise it will cause fire, electric shock and operation failure.



If any liquid enters the sewing machine (head or control box), turn off the power supply immediately, pull the plug out of the socket, and contact the vendor or senior technicians.

Be Careful

Use Environment

Please don't use in the environment with strong electrical interference sources such as power line interference and electrostatic interference.

Strong electrical interference sources may affect the correct operation of sewing machines.

The fluctuation of power supply voltage should be used in the environment of rated voltage less than $\pm 10\%$.

The large fluctuation of voltage will affect the correct operation of sewing machine.

The power supply capacity should be greater than the power consumption of the sewing machine. Insufficient power supply capacity will affect the correct operation of sewing machine.

The ambient temperature should be used in the range of 5-35 degrees Celsius.

Low or high temperature will affect the correct operation of sewing machine.

Relative humidity should be in the range of 45% - 85%, and the equipment will not form condensation environment. Dry or wet environment and dew will affect the correct operation of sewing machine.

In case of thunderstorm, turn off the power switch and pull the power plug off the socket. Lightning may affect the correct operation of sewing machine.

Do not connect devices other than USB memory to USB connection ports. Otherwise, it may lead to failure.



Install



Ask trained technicians to install sewing machines.

Please commission the purchase shop or electrical professionals for electrical wiring.

The sewing machine weighs about 35Kg. Installation must be completed by more than two people.



Please do not connect the power supply before the installation is completed. If you step on the pedal by mistake, the sewing machine will cause injury.

Please unplug the plug after cutting off the power supply. Otherwise, it will easily become the cause of the failure of the control box.



It must be grounded.

Insufficient ground connection is the cause of electric shock or misoperation.

When fixing the cable, do not bend the cable excessively or fix it too tightly with clamps, which may cause fire or electric shock.



If a worktable with casters is used, the casters should be fixed so that they cannot move.

When the head of the sewing machine falls down, please make sure that the worktable is fixed and not moved at will. Accidents such as foot clamping have occurred in the movement of worktable, which is the cause of personal accidents.



When the sewing machine head falls down or stands up, please operate with both hands.

One-handed operation can easily cause injury if the weight of the sewing machine slips.



When lubricating oil and butter are used, it is necessary to wear protective glasses and gloves to prevent lubricating oil from falling into serious or sticking to the skin, which is the cause of inflammation.

In addition, lubricants or butter should not be drunk, otherwise vomiting and diarrhea will occur.

Keep oil out of reach of children

⚠ 注意

缝 纫



本缝纫机仅限于接受过安全操作培训的人员使用。



本缝纫机不能用于除缝纫外的任何其他用途。

使用缝纫机时必须戴上保护眼镜。

如果不戴保护眼镜，断针时就会有危险，机针的折断部分可能会弹入眼睛并造成伤害。



发生下列情况时，请切断电源。

否则误踩下脚踏板时，缝纫机动作会导致受伤。

- 机针穿线时
- 更换机针或梭芯时
- 缝纫机不使用，或人离开缝纫机时

如果使用带小脚轮的工作台，则应该固定小脚轮，使其不能移动。



为了安全起见，在使用本缝纫机之前，请安 保 护 置。如果未安 这些安全 置就使用缝纫机，会造成人身伤害及缝纫机损坏。



缝纫过程中，不要触摸任何运动部件或将物件靠在运动部件上，因为这会导致人员受伤或缝纫机损坏。



缝纫机头倒下时，请一定要固定工作台，不可使其随意移动。

工作台移动易发生脚等被夹住之事故，是导致人身事故的原因。



缝纫机头倒下或竖起时，请用双手进行操作。

单手操作时因缝纫机的重量万一滑落易导致受伤。

如果缝纫机操作中发生误动作，或听到异常的噪音或闻到异常的气味，应立即切断电源。然后请与购买商店或受过培训的技术人员联系。

如果缝纫机出现故障，请与购买商店或受过培训的技术人员联系。

清 洁



在开始清洁作业前，请切断电源。

如果误踩下脚踏板时，缝纫机动作会导致人员受伤。



缝纫机头倒下时，请一定要固定工作台，不可使其随意移动。

工作台移动易发生脚等被夹住之事故，是导致人身事故的原因。



缝纫机头倒下或竖起时，请用双手进行操作。

单手操作时因缝纫机的重量万一滑落易导致受伤。



使用润滑油和黄油时，务必戴好保护眼镜和保护手套等，以防润滑油落入眼中或沾在皮肤上，这是引起发炎的原因。

另外，润滑油或黄油不能饮用，否则会引起呕吐和腹泻。

将油放在小孩拿不到的地方。

保 养 和 检 查



只有经过训练的技术人员才能进行缝纫机的维修、保养和检查。

与电气有关的维修、保养和检查请委托购买商店或电气专业人员进行。



发生下列情况时，请关闭电源。并从电源插座上拔下插头。

否则误踩下脚踏板时，缝纫机动作会导致受伤。

- 检查、调整和维修
- 更换旋梭，切刀等易损零部件



打开马达罩盖前，务必先关闭电源，等待一分钟后，再执行操作。

触摸马达表面可能会导致烫伤。



在必须接上电源开关进行调整时，请务必切换到保养模式。

务必十分小心遵守所有的安全注意事项。



缝纫机头倒下时，请一定要固定工作台，不可使其随意移动。

工作台移动易发生脚等被夹住之事故，是导致人身事故的原因。



缝纫机头倒下或竖起时，请用双手进行操作。

单手操作时因缝纫机的重量万一滑落易导致受伤。

更换零件或安 可选附件时，请务必仅使用正品零件。

本公司将不承担由使用非正品零件而造成的任何事故或故障责任。

取下的安全保护 置，再次安 时，请务必安在原位上，并检查能否正常的发挥作用。



为了防止发生事故及故障，请勿擅自改造本缝纫机。

本公司将不承担由改造本缝纫机而造成的任何事故或故障责任。

⚠ 注意

缝 纫



本缝纫机仅限于接受过安全操作培训的人员使用。



本缝纫机不能用于除缝纫外的任何其他用途。

使用缝纫机时必须戴上保护眼镜。

如果不戴保护眼镜，断针时就会有危险，机针的折断部分可能会弹入眼睛并造成伤害。



发生下列情况时，请切断电源。

否则误踩下脚踏板时，缝纫机动作会导致受伤。

- 机针穿线时
- 更换机针或梭芯时
- 缝纫机不使用，或人离开缝纫机时

如果使用带小脚轮的工作台，则应该固定小脚轮，使其不能移动。



为了安全起见，在使用本缝纫机之前，请安 保 护 置。如果未安 这些安全 置就使用缝纫机，会造成人身伤害及缝纫机损坏。



缝纫过程中，不要触摸任何运动部件或将物件靠在运动部件上，因为这会导致人员受伤或缝纫机损坏。



缝纫机头倒下时，请一定要固定工作台，不可使其随意移动。

工作台移动易发生脚等被夹住之事故，是导致人身事故的原因。



缝纫机头倒下或竖起时，请用双手进行操作。

单手操作时因缝纫机的重量万一滑落易导致受伤。

如果缝纫机操作中发生误动作，或听到异常的噪音或闻到异常的气味，应立即切断电源。然后请与购买商店或受过培训的技术人员联系。

如果缝纫机出现故障，请与购买商店或受过培训的技术人员联系。

清 洁



在开始清洁作业前，请切断电源。

如果误踩下脚踏板时，缝纫机动作会导致人员受伤。



缝纫机头倒下时，请一定要固定工作台，不可使其随意移动。

工作台移动易发生脚等被夹住之事故，是导致人身事故的原因。



缝纫机头倒下或竖起时，请用双手进行操作。

单手操作时因缝纫机的重量万一滑落易导致受伤。



使用润滑油和黄油时，务必戴好保护眼镜和保护手套等，以防润滑油落入眼中或沾在皮肤上，这是引起发炎的原因。

另外，润滑油或黄油不能饮用，否则会引起呕吐和腹泻。

将油放在小孩拿不到的地方。

保 养 和 检 查



只有经过训练的技术人员才能进行缝纫机的维修、保养和检查。

与电气有关的维修、保养和检查请委托购买商店或电气专业人员进行。



发生下列情况时，请关闭电源。并从电源插座上拔下插头。

否则误踩下脚踏板时，缝纫机动作会导致受伤。

- 检查、调整和维修
- 更换旋梭，切刀等易损零部件



打开马达罩盖前，务必先关闭电源，等待一分钟后，再执行操作。

触摸马达表面可能会导致烫伤。



在必须接上电源开关进行调整时，请务必切换到保养模式。

务必十分小心遵守所有的安全注意事项。



缝纫机头倒下时，请一定要固定工作台，不可使其随意移动。

工作台移动易发生脚等被夹住之事故，是导致人身事故的原因。



缝纫机头倒下或竖起时，请用双手进行操作。

单手操作时因缝纫机的重量万一滑落易导致受伤。

更换零件或安 可选附件时，请务必仅使用正品零件。

本公司将不承担由使用非正品零件而造成的任何事故或故障责任。

取下的安全保护 置，再次安 时，请务必安在原位上，并检查能否正常的发挥作用。



为了防止发生事故及故障，请勿擅自改造本缝纫机。

本公司将不承担由改造本缝纫机而造成的任何事故或故障责任。

[2] 警告标签

缝纫机上有下列警告标签。

当使用缝纫机时，请遵守标签上的说明。如果标签脱落或模糊不清，请和购买商店联系。

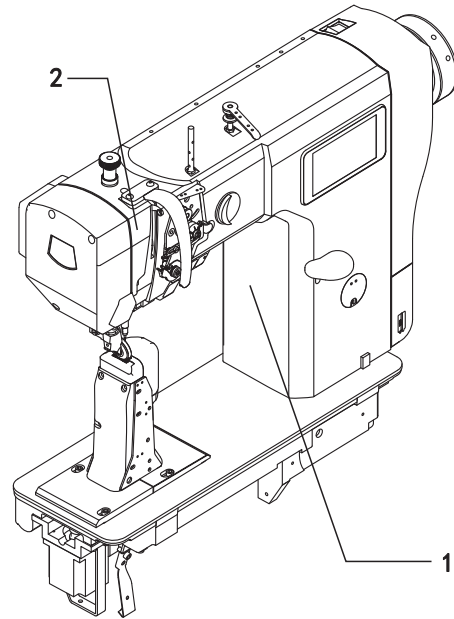
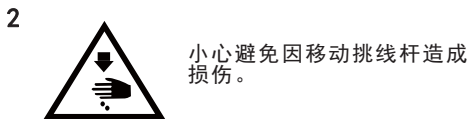
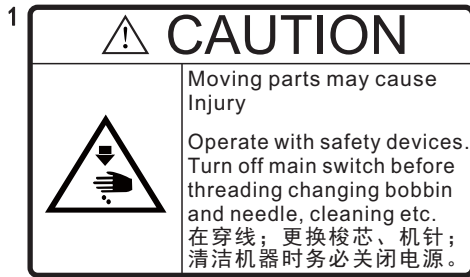

[2] Warning Label

The following warning labels are on the sewing machine

When using the sewing machine, please follow the instructions on the label. If the label falls off or is ambiguous, please contact the purchase shop.

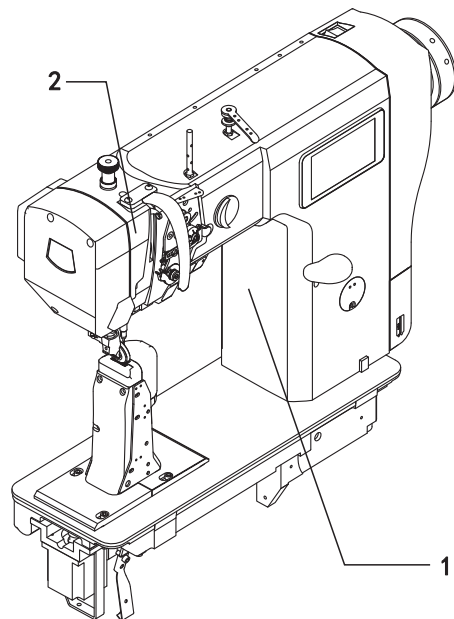
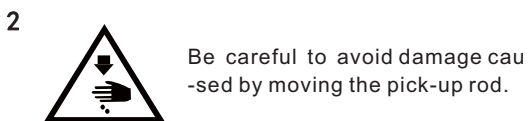
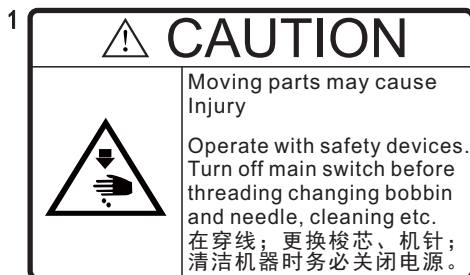

零件手册及说明书 使用说明

1. 本手册适用于封面上所示不同系列的缝纫机；
2. 本手册为2018年10月的版本；
3. 部分零件设计上的改变不预先通知用户；

Notes for using this operation manual and parts book

1. This book is applicable to sewing machines which have the same plate number as shown on the cover of this book.
2. This book was prepared based on information available in October 2018.
3. Parts are subject to changes in design without prior notice.

目 录

目 录	章	页
1	安全	1 - 1
1.01	注意安全图标	1 - 1
1.02	工作中的特殊注意事项	1 - 1
1.03	危险警告	1 - 2
2	应用规定	2 - 1
3	技术 据	3 - 1
3.01	9630, 9640	3 - 1
3.02	针和线	3 - 2
3.03	可供货的机型及分机型	3 - 2
4	工作图表	4 - 1
5	操作元件	5 - 1
5.01	机头按键(仅用于安装有-D3的机器)	5 - 1
5.02	踏板	5 - 1
5.03	滚轮压脚扳手	5 - 1
5.04	膝提杆	5 - 2
5.05	滚轮压脚向外摆动	5 - 2
6	安装和试车	6 - 1
6.01	安装	6 - 1
6.01.01	台板高度的调整	6 - 1
6.02	安装线架	6 - 2
6.03	安装翻转保险	6 - 2
6.04	试车	6 - 3
6.05	倾斜的支承块	6 - 3
6.06	台板开槽部位尺寸	6 - 4
6.07	安装台板	6 - 4
7	机器准备	7 - 1
7.01	在9630系列机型上装机针	7 - 1
7.02	在9640系列机型上装机针	7 - 2
7.03	绕梭心线;调节梭心线的初始张力	7 - 3
7.04	取出/装入梭壳	7 - 4

目 录

7.05	梭壳穿线/调节梭心线的张力	7 - 4
7.06	在9630机型上穿针线并调节针线张力	7 - 5
7.07	在9640机型上穿针线并调节针线张力	7 - 6
7.08	设置线迹长度	7 - 7
8	维护与保养	8 - 1
8.01	清洁	8 - 1
8.02	给旋梭加油	8 - 2
8.03	旋梭润滑油盒	8 - 3
8.04	给线润滑系统的油盒加油	8 - 3
8.05	给伞齿轮副润滑	8 - 4
9	调整	9 - 1
9.01	对调整工作的提示	9 - 1
9.02	工具、量规和其它辅助材料	9 - 1
9.03	调整基础机器	9 - 2
9.03.01	在9630机型上从缝纫方向上看机针的位置	9 - 2
9.03.02	在9640机型上从缝纫方向看机针的位置	9 - 3
9.03.03	初步调整针的高度	9 - 4
9.03.04	在9640机型上针的上 ,旋梭到针的距离,针的高度和护针器	9 - 5
9.03.05	在9630S和9630机型上针的上 ,旋梭到针的距离,针的高度和护针器	9 - 7
9.03.06	在9640机型上从垂直于缝纫方向看机针的位置	9 - 9
9.03.07	在9630机型上从垂直于缝纫方向看机针的位置	9 - 10
9.03.08	开梭器的高度和行程	9 - 11
9.03.09	在9640机型上进给轮高度的调整	9 - 12
9.03.10	在9630机型上进给轮高度的调整	9 - 13
9.03.11	滚轮压脚和进给轮之间的距离	9 - 14
9.03.12	滚轮压脚调整	9 - 15
9.03.13	正倒缝重合度调整	9 - 16
9.03.14	压料器(仅9640机型才有)	9 - 18
9.03.15	膝提杆	9 - 19
9.03.16	针线松线调整	9 - 20
9.03.17	挑线簧调整(9630机型)	9 - 21
9.03.18	挑线簧调整(9640机型)	9 - 22
9.03.19	绕线器	9 - 24
9.03.20	滚轮压脚的压力调整	9 - 25
9.03.21	润滑	9 - 26
9.03.22	安全联轴器复位	9 - 27
9.04	剪线器-D的调整	9 - 28
9.04.01	滚子杠杆的静止位置/控制凸轮的径向位置调整	9 - 28

目 录

9.04.02	捕线器架的位置调整.....	9 - 29
9.04.03	捕线器与针板间的距离	9 - 30
9.04.04	捕线器位置调整	9 - 31
9.04.05	切刀位置和切刀压力	9 - 32
9.04.06	梭心线夹持弹簧	9 - 33
9.04.07	手动剪线试验	9 - 34
9.04.08	联动杆调整(仅 9640机型有)	9 - 35
9.04.09	机针在针孔中的位置 (仅对于 9630机型)	9 - 36

Index

Contexts	Chapter - Page
1	Safety 1 - 1
1.01	Safety symbols 1 - 1
1.02	Important points for the user..... 1 - 1
1.03	Danger 1 - 2
2	Proper use 2 - 1
3	Specifications 3 - 1
3.01	9630, 9640 3 - 1
3.02	Needles and threads 3 - 2
3.03	Possible models and 3 - 2
4	Explanation of symbols 4 - 1
5	Controls 5 - 1
5.01	Keys on the machine head (only for machines with -D3) 5 - 1
5.02	Pedal 5 - 1
5.03	Lever for lifting roller presser 5 - 1
5.04	Knee lever 5 - 2
5.05	Swing out roller presser 5 - 2
6	Installation and commissioning 6 - 1
6.01	Installation..... 6 - 1
6.01.01	Adjusting the table height..... 6 - 1
6.02	Fitting the reel stand 6 - 2
6.03	Kippsichtigtes..... 6 - 2
6.04	Commissioning 6 - 3
6.05	Tilted work base 6 - 3
6.06	Tilted work base 6 - 4
6.07	Mounting the table top 6 - 4
7	Preparation 7 - 1
7.01	Inserting needle on model 9630 7 - 1
7.02	Inserting the needle on model 9640 7 - 2

Index

7.03	Winding the bobbin thread; adjusting the primary thread tension	7 - 3
7.04	Removing/Inserting the bobbin case	7 - 4
7.05	Threading the bobbin case/Adjusting the bobbin thread tension	7 - 4
7.06	Threading the needle thread and regulating its tension on model 9630.....	7 - 5
7.07	Threading the needle thread and regulating its tension on model 9640	7 - 6
7.08	Setting the stitch length	7 - 7
8	Care and maintenance	8 - 1
8.01	Cleaning	8 - 1
8.02	Oiling the hook	8 - 2
8.03	Oil bowl for hook lubrication	8 - 3
8.04	Filling the oil reservoir of the thread lubrication unit.....	8 - 3
8.05	Lubricating the bevel gears.....	8 - 4
9	Adjustment	9 - 1
9.01	Notes on adjustment	9 - 1
9.02	Tools, gauges and other accessories	9 - 1
9.03	Adjusting the basic machine	9 - 2
9.03.01	Needle position in sewing direction on the 9630.....	9 - 2
9.03.02	Needle position in sewing direction on the 9640.....	9 - 3
9.03.03	Preliminary adjustment of the needle height	9 - 4
9.03.04	Needle rise, hook clearance, needle height and needle guard on the 9640.....	9 - 5
9.03.05	Needle rise, hook clearance, needle height and needle guard on the 9630	9 - 7
9.03.06	Needle position crosswise to sewing direction on the 9640	9 - 9
9.03.07	Needle position crosswise to sewing direction on the 9630.....	9 - 10
9.03.08	Height and stroke of the bobbin case opener	9 - 11
9.03.09	Height of the feed wheel on the 9640	9 - 12
9.03.10	Height of the feed wheel on the 9630	9 - 13
9.03.11	Clearance between roller presser and feed wheel	9 - 14
9.03.12	Roller presser	9 - 15
9.03.13	Adjusting the contact ratio of forward-back swing	9 - 16
9.03.14	Retainer(only on 9640)	9 - 18
9.03.15	Knee lever	9 - 19
9.03.16	Needle thread tension release	9 - 20
9.03.17	Thread check spring (9630)	9 - 21

Index

9.03.18	Thread check springs (9640)	9 - 22
9.03.19	Bobbin winder	9 - 24
9.03.20	Pressure of roller presser	9 - 25
9.03.21	Lubrication	9 - 26
9.03.22	Re-engage safety coupling	9 - 27
9.04	Adjusting the thread trimmer -D	9 - 28
9.04.01	Resting position of the roller lever/radial position of the control cam ...	9 - 28
9.04.02	Position of the thread catcher holder	9 - 29
9.04.03	Distance between thread catcher and needle plate	9 - 30
9.04.04	Position of the thread catcher	9 - 31
9.04.05	Knife position and knife pressure	9 - 32
9.04.06	Bobbin thread retaining spring	9 - 33
9.04.07	Manual cutting test	9 - 34
9.04.08	Releasing the tension	9 - 35
9.04.09	Linkage rod (only for 9640)	9 - 36
9.04.10	Needle in needle hole (only for 9630).....	9 - 37

1. 安全 Safety

1.01 注意安全图标 Safety symbols



危险位置! Danger!
特别注意点。Points to be observed



对操作人员及专业人员有受伤危险!
Danger of injury for operating and specialist personnel!

注意 Caution

不允许在没有护指器和安全装置的情况下工作。
在穿线, 换梭心, 换针, 清洁等工作之前, 关闭总开关。

Do not operate without finger guard and safety devices.

Before threading, changing bobbin and needle, cleaning etc's witch off main switch.

1.02 工作中的特殊注意事项 Important points for the user

- 使用说明书属于机器一部分, 因此操作人员必须随时可以取用。
- 在首次试车调试之前, 必须阅读使用说明书。
- 必须对操作人员及专业人员进行有关机器的防护装置及安全工作方面的培训。
- 机器的使用者有责任保证机器在正常的无故障状态下运作。
- 机器的使用者必须保证不拆除任何安全装置或使它们失效。
- 机器的使用者必须注意, 只允许被授权的人员在机器上工作。
- **This Instruction Manual is a component of the machine and must be available to the operating personnel at all times.**
- **The Instruction Manual must be read before operating the machine for the first time.**
- **The operating and specialist personnel must to be instructed in the safeguards of the machine and safe work methods.**
- **It is the duty of the user to operate the machine in perfect running order.**
- **It is the obligation of the user to ensure that none of the safety mechanisms are removed or deactivated.**
- **It is the obligation of the user to ensure that only authorized persons operate and work on the machine.**

安全 Safety

1.03 危险警告 Danger



机器运作过程中，必须在机器的前后各保留1m的自由工作范围，以保证人员随时地、不受阻地接近机器。

A working area of 1 meter is to be kept free both in front of and behind the machine in operation so that the machine is always easily accessible.



在缝纫过程中，不许在缝纫针区域抓取任何东西！有被针扎伤的危险！
Never reach into the sewing area while sewing! Danger of injury by the needle!



调整工作过程中，不许在工作台上放任何物品！物品有被卡住或被摔走的可能！有被四下乱飞的物品伤害的危险！

Never leave objects on the table while adjusting the machine settings! Objects can become trapped or be slung away! Danger of injury!



不许开动没有支承件1的机器！因为机头非常重，当向后倾斜时，机器有向后翻倒的危险！

Do not operate the machine without support 1! Danger due to top-heavy sewing head! Machine can tip over backwards when tilted!

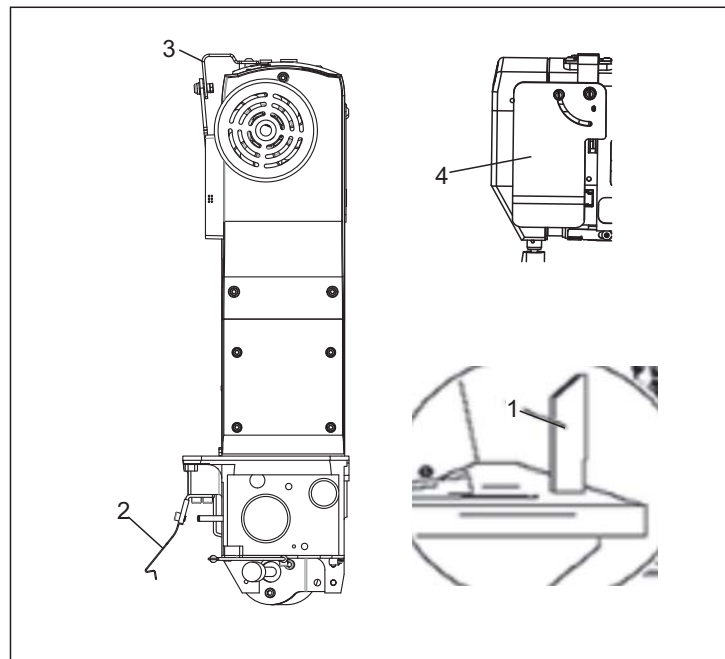



在向后倾斜机器前关闭总开关！
有被机器意外地起动伤害的危险！
Switch the machine off before tilting it backwards!
Danger of injury if the machine is started accidentally!



不许开动没有挑线杆护罩3的机器！
有被挑线杆的动作伤害的危险！
Do not operate the machine without its take-up-lever guard 3!
Danger of injury due to the motion of the take-up lever!



带有线润滑器的机器不许在护眼装置4放下前开动！护眼装置4保护眼睛免受来自线润滑的油微粒伤害。
On machines with thread lubricator, only operate the machine with the eye guard 4 lowered! The eye guard 4 protects the eyes from oil particles from the thread lubrication!



不许开动没有翻转保险2的机器！
有在机头和抬板之间被挤伤的危险！
Do not operate the machine without tilt lock 2!
Danger of crushing between sewing head and table top!

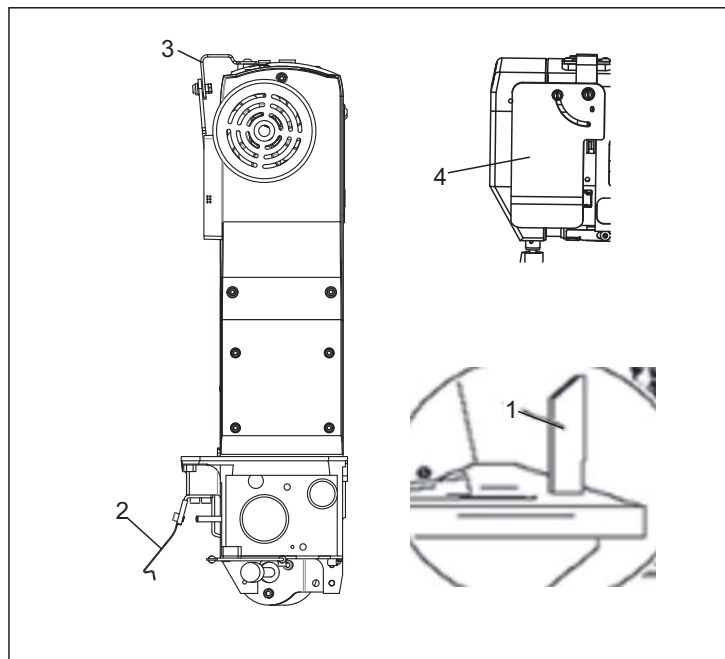

应用规定 Proper use

2 应用规定 Proper use

9640系列 是双针、高速，带有被动送料轮、滚轮压脚的柱式底板缝纫机。

Is a double-needle, high-speed post bed sewing machine with driven feed wheel and roller presser.

9630系列 是单针、高速，带有被动送料轮、滚轮压脚和同步针的柱式底板缝纫机（柱式底板在针右边）。

Is a single needle, high-speed post bed sewing machine (post to the right of the needle) with driven feed wheel and roller presser and synchronized needle.

这些机器用于皮革制品和装饰工业中完成锁式线迹缝纫。

The machines are used for sewing lockstitch seams in the leather and upholstery industries.



任何未经机器制造商准许的应用，都被视为违反规定！对由于违反规定的应用引起的损失，机器制造商不负任何责任！属于应用规定的内容也包括遵守由机器制造商所给出的各种操作方法、调节方法、保养和修理措施！

Any use of these machines which is not approved by the manufacturer shall be considered as improper use! The manufacturer shall not be liable for any damage arising out of improper use! Proper use shall also be considered to include compliance with the operation, adjustment, service and repair measures specified by the manufacturer!

3 技术 据 Specifications

3.01 9630 , 9640 ▲

线迹型式 Stitch type.....301 (锁式线迹/lockstitch)
在滚轮压脚下通过高度 Clearance under roller presser..... 7 mm
空间宽度 Clearance width 245 mm
空间高度 Clearance height.....115 mm
柱式底板高度 Post height 180 mm

缝纫机机头尺寸 Sewing head dimensions

长度 Length..... 大约/approx. 615 mm
宽度 Width 大约/approx. 240 mm
高度(台板以上) Height (above table) 大约/approx. 500 mm
底板尺度 Bedplate dimensions..... 518 x 177 mm

最高速度 Max.speed

9630 3000 线迹/分/spm ◆
9640..... 2000 线迹/分/spm ◆

接线 据 Connection data

工作电压 Operating voltage 220 V ± 10%, 50/60 Hz
最大耗用功率 Max.power consumption 1.2 kVA
保险丝 Fuse protection 1 x 16 A, 内置/insert

噪音 据 Noise data

在工作场所以合适的速度工作发出的噪音水平

Emission sound level at the work place at appropriate speed

(噪音测量按照DIN 45 635-48-A-1, ISO 11204, ISO 3744, ISO4871)

(Noise measurement in accordance with DIN 45 635-48-A-1, ISO

11204, ISO 3744, ISO4871)

9630 在速度2400线迹/分: $L_{pA} \leq 79$ dB(A) ■

9630 at a speed of 2400spm $L_{pA} \leq 79$ dB(A) ■

9640 在速度1600线迹/分: $L_{pA} \leq 75$ dB(A) ■

9640- at a speed of 1600spm $L_{pA} \leq 75$ dB(A) ■

9630 在速度1600线迹/分: $L_{pA} \leq 73$ dB(A) ■

9630 at a speed of 1600spm $L_{pA} \leq 73$ dB(A) ■

机器净重 Net weight of sewing head..... 大约/approx. 61 kg

机器毛重 Gross weight of sewing head..... 大约/approx. 71 kg

▲ 保留技术更改的权力 Subject to alteration

◆ 取决于材料、工序、和针距 Dependent on material, work operation and stitch length

■ $K_{pA} = 2,5$ dB

技术 据 Specifications

3.02 针和线 Needles and threads

机型	线规格▲ (Nm) 最大▲ 人造纤维线	针规格 单位1/100mm	9640 机针系统	9630 机针系统
M	40/3	90 / 14	134-35	134
H	15/3	120 / 14	134-35	134

Model	Thread thickness (Nm) max. Synthetics	▲Needle thickness 1/100mm	9640 Needle system	9630 Needle system
M	40/3	90 / 14	134-35	134
H	15/3	120 / 14	134-35	134

▲ 或使用具有相同强度的其它种类的线
▲ or similar strengths of other types of thread

注明: M 薄料 Note: M lightweight materials

H 厚料 H Medium-heavy materials

3.03 可供货的机型及分机型 Possible models and subclasses

9630,9640

M型.....适用于缝纫轻薄材料和中厚料
Model M.....For sewing lightweight and medium-weight materials

H型.....适用于缝纫厚材料
Model H.....For sewing medium-heavy materials

附加设备 Additional equipment

»分机型-D.....自动剪线装置
Subclass-D..... Automatic edge trimmer

»分机型 D3.....自动剪线装置、自动抬压脚装置、倒缝装置
Subclass-D3..... Automatic edge trimmer, automatic presser
foot lifter, backtacking device.

工作图标 Explanation of symbols

4 工作图表 Explanation of symbols

在使用说明书中，所要进行的工作和重要信息都由相应的图标表达所使用的图标具有下列含义

In this Instruction Manual, work to be carried out or important information is accentuated by symbols which have the following meanings:



提示，信息

Note, information



清洁，保养

Cleaning, care



润滑

Lubrication

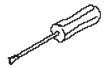

维护，修理，调整，维修（只能由专业人员完成的工作）
Maintenance, repairs, adjustment, service work (only to be carried out by technical staff)

操作元件 Controls

5 操作元件 Controls

5.01 机头按键 (仅用于安装有-D3的机器)

Keys on the machine head (only for machines with-D3 9630)

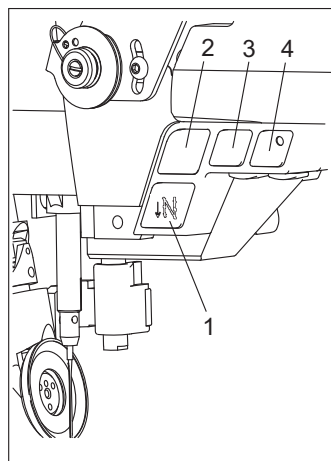

- 在缝纫过程中，只要按下按键1，机器的缝纫方向就反转。
- 按键2设置第二针距，按键3补针，按键4急停。
- As long as key 1 is pressed during sewing, the machine sews in reverse direction.
- Keys 2 is use to setting second stitch length, key 3 is use to compensate stitch, key 4 is use to scram.

5.02 踏板 Pedal

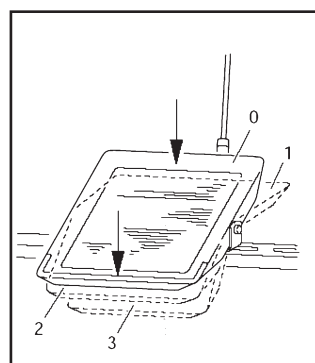

- 0= 静止位置 Neutral position
- 1= 缝纫 Sewing
- 2= 抬起滚轮压脚 (在安装有 -D3、9630的机器上)
Raiser roller presser (on machines with-D3、9630..)
- 3= 剪线 (在安装有-D..的机器上)
Trim sewing threads (on machines with-D..)

5.03 滚轮压脚扳手 Lever for lifting roller presser

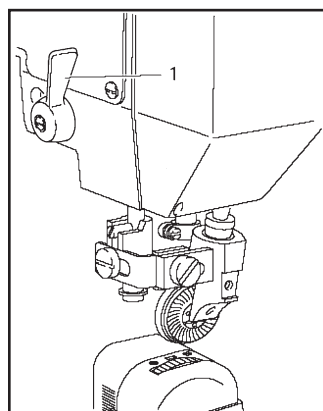

- 可以通过转动扳手1抬起滚轮压脚。
- The roller presser can be raised by turning lever 1.

5.04 膝提杆 Knee lever

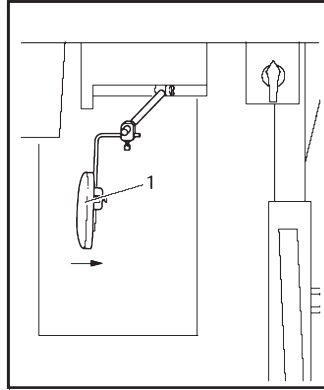

- 可以通过向箭头所示方向挤压膝提杆1, 来抬起滚轮压脚。
- The roller presser can be raised by pressing the knee lever 1 in the direction of the arrow.

5.05 滚轮压脚向外摆动 Swing out roller presser

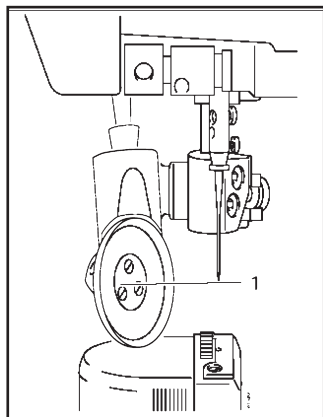

- 当滚轮压脚抬起后, 可以通过向下轻拉它, 使其向外摆动。
- When the roller presser is raised, it can be swung out by pulling it lightly downwards.

安装和试车 Installation and commissioning

6

安装和试车

Installation and commissioning



只允许有资格的人员对机器进行安装和试车！！
这里必须遵守所有有关的安全规定！

The machine must only be installed and commissioned by qualified personnel!

All relevant safety regulations must be strictly adhered to!



如果缝纫机不带台板供货，则工作时所用的机架和台板必须保证能够承受机器和电机的重量。

在缝纫运行中的台座也要保证牢固而且稳定。

If the machine is delivered without a table, be sure to use a stand and table top that can hold the weight of the machine with its motor.

It is very important to ensure that the stand of the machine is firm and steady, also during sewing.

6.01

安装 Installation

在机器安装地点，必须有与机器相符的电源接口。

在机器安装地点，必须有平整、坚固的地面，以及充分的照明

The site where the machine is installed must be provided with suitable connections for electric current.

It must be ensured that the standing surface of the machine site is firm and horizontal, and that sufficient lighting is provided for.



由于包装和运输的原因，台板高度的调整如下所述。

For packing and transportation reasons the table top is in the lowered position. The table height is adjusted as described below.

6.01.01

台板高度的调整

Adjusting the table height

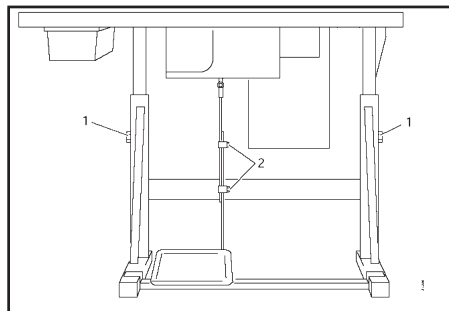

● 松开螺钉1和2，并将台板调整至所需的高度。

● 将螺钉1牢固地拧紧。

● 将踏板调至所需的位置，并且将螺钉2拧紧。

● Loosen screws 1 and 2 and set the table height as required.

● Firmly tighten screw 1.

● Set the required pedal position and tighten screw 2.

安装和试车 Installation and commissioning

6.02 安装线架 Fitting the reel stand

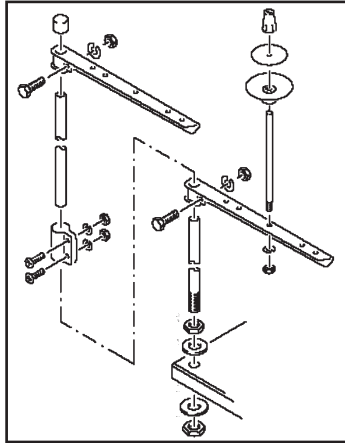

- 如图所示安装线架。
- 然后将线架插入台板的孔中并用随带的螺母可靠地固定。
- Fit the reel stand as shown in Fig.
- Afterwards insert the stand in the hole of the table top and secure it with the nuts provided.

6.03 安装翻转保险

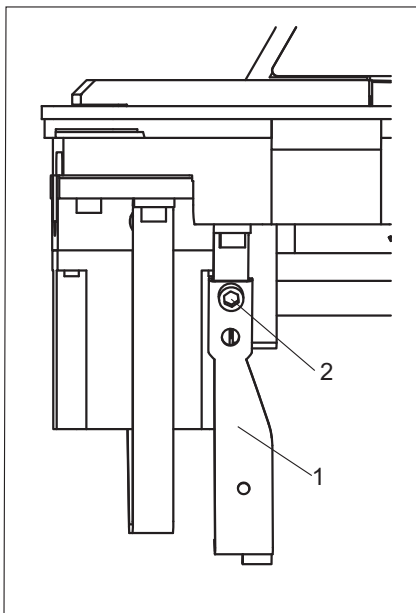

Maschine ausschalten!
Verletzungsgefahr durch unbeabsichtigtes
Anlaufen der Maschine!

- Die im zubehör befindliche kipp-sicherung1 mit schraube 2 anschrauben.



Maschine nicht ohne kipp-sicherung 1
betreiben! Sicherung 1 betreiben!
Quetschgefahr zwischen oberteil und
tischplatte!



关闭机器电源总开关
有被机器意外地起动伤害的危险!

- 用螺栓2固定翻转保险1（随附件供货）



不许开动没有翻转保险1的机器！有在机头
和抬板之间被挤伤的危险！

安装和试车 Installation and commissioning

6.04 试车 Commissioning

- 检查机器是否有损坏，特别是电缆线有无损坏。
- 彻底清洁机器，然后涂油或加油（请参见第11章“维护与保养”）
- 由专业人员检查。机器的电动机是否允许用已有的电源电压驱动，电动机是否正确地在接线盒里接线。在任何有出入的情况下，决不许开车。
- Check the machine, particularly the electrical wiring for any damage.
- Clean the machine thoroughly and then oil it or fill oil in (see Chapter 11 Care and maintenance).
- Have a mechanic check whether the motor of the machine can be operated with the available power supply, and that the motor is correctly connected in the junction box. If there are any discrepancies, the machine must not be operated under any circumstances.



机器只允许接在有接地线的插座上！

The machine only be connected to an earthed socket!

- 机器运行时，手轮必须向操作人员方向旋转。如果不对，由专业人员将电动机换接。
- When the machine is running, the balance wheel must turn towards the operator. If it does not, the motor connection must be changed by a mechanic.

6.05 倾斜的支承块

Tilted work base

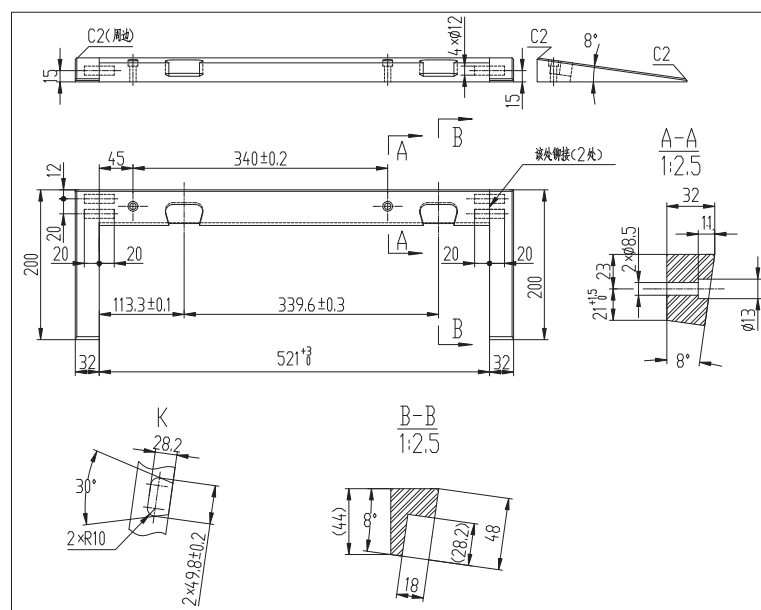

安装和试车 Installation and commissioning

6.06 台板开槽部位尺寸 Tilted work base

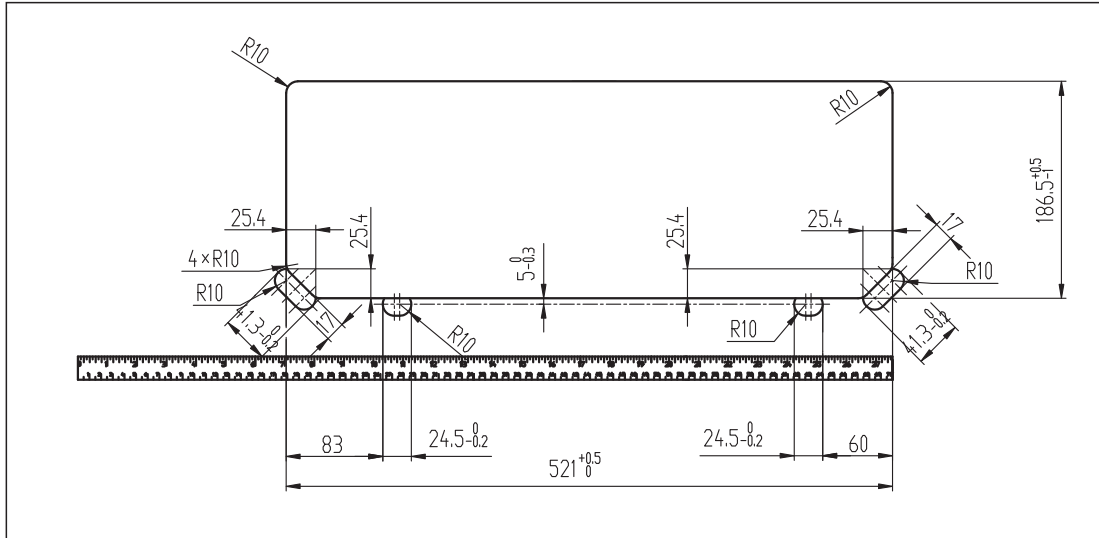

6.07 安装台板 Mounting the table top

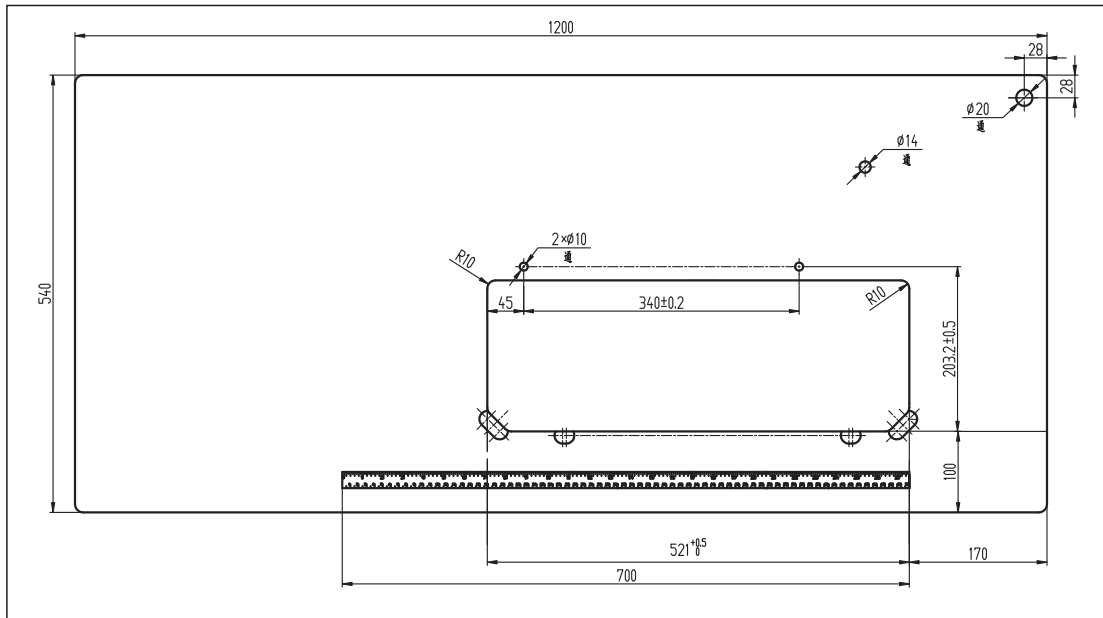

机器准备 Preparation

7 机器准备 Preparation



必须遵守本说明书中所有的规定和提示。
特别注意所有的安全规定！

All instructions and regulations in this Instruction Manual must be observed .

Special attention must be paid to all safety regulations!



所有机器准备工作只允许由受过相应培训的人员完成。
在所有的机器准备工作时，必须通过关闭总开关或者从电源插座上拔掉插头，以使机器断电。

All setting-up work must only be carried out by personnel with the appropriate training. For all setting-up work the machine must be disconnected from its power supply by turning off the on/off switch, or removing the plug from the electric power socket.

7.01

在9630机型上装机针

Inserting needle on model 9630



关闭机器电源！有被机器意外地启动伤害的危险！

Switch the machine off! Danger of injury if the machine is started accidentally!

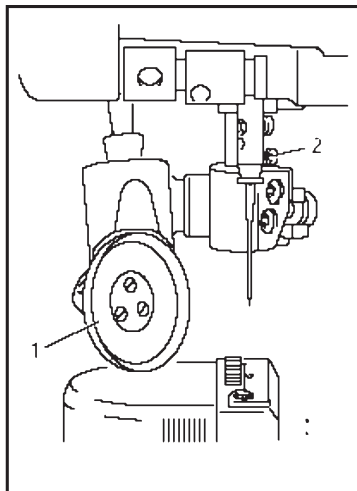

只使用**134**系统的机针。

Only use needles of system **134**

- 抬起滚轮压脚1并将其向外摆动。
- 松开螺钉2并尽可能深地插入机针。；对于**9630**机型，长针槽必须面向左边。
- 拧紧螺钉2并将滚轮压脚摆回到原位置。
- Raise the roller presser **1** and swing it out.
- Loosen screw **2** and insert the needles as far as possible. The long groove must face to the left on model **9630**.
- Tighten screw **2** and swing roller presser **1** back to position.



机针的选用取决于机器的型号、线和所缝纫的材料（参见第3.02节“针和线”）

The Choice of needle depends on the model of the machine and the thread and material used (see Chapter 3.02 Needles and threads).

7.02 在9640机型上装机针

Inserting the needle on model 9640



关闭机器电源！ 有被机器意外地起动伤害的危险！
Switch the machine off! Danger of injury if the machine is started accidentally !

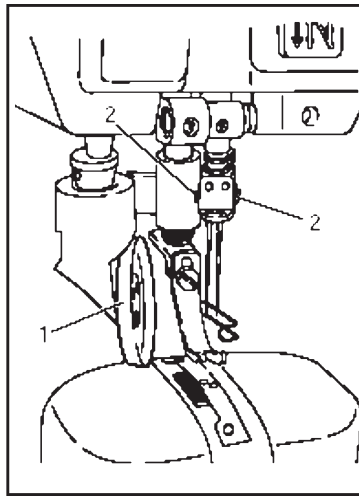

只使用**134-35**系统的机针。

Only use needles of system **134-35**.

- 抬起滚轮压脚**1**并将其向外摆动。
- 松开螺钉**2**并插入机针，使左边机针的长针槽面向右边；右边机针的长针槽面向左边。
- 拧紧螺钉**2**并将滚轮压脚摆回到原位置。
- Raise the roller presser **1** and swing it out.
- Loosen screws **2** and insert the needles so that the long groove of the left needle is facing right, and that of the right needle is facing left.
- Tighten screws **2** and swing roller presser **1** back into position.



机针的选用取决于机器的型号、线和所缝纫的材料（参见第3.02节“针和线”）

The Choice of needle depends on the model of the machine and the thread and material used (see **Chapter 3.02 Needles and threads**).

机器准备 Preparation

7.03 梭心线：调节梭心线的初始张力

Winding the bobbin thread; adjusting the primary thread tension



- 将一个空的梭心1安装到绕线器轴2上。
- 如图所示9-03给梭心穿线，并将线顺时针方向在梭心上绕几圈。
- 当同时压下绕线器轴2和杠杆3，启动绕线器。
- Place an empty bobbin 1 into bobbin winder spindle 2.
- Thread the bobbin as shown in Fig. And wind it clockwise around bobbin 1 a few times
- Switch on the bobbin winder while pressing bobbin winder spindle 2 and lever 3.



在缝纫过程中，梭心绕线。
The bobbin is filled up during sewing.

- 在梭心1上的线张力可以用滚花螺纹4进行调整。
- 当梭心绕满线后，绕线器自动停止。
- The thread tension of bobbin 1 can be adjusted by knurled screw 4.
- The bobbin winder stops automatically when bobbin 1 is full.

如果绕线不均匀：
If the thread is wound unevenly:

- 松开螺母5。 Loosen nut 5.
- 相应地转动导线板6。 Turn thread guide 6 accordingly.
- 拧紧螺母5。 Tighten nut 5.

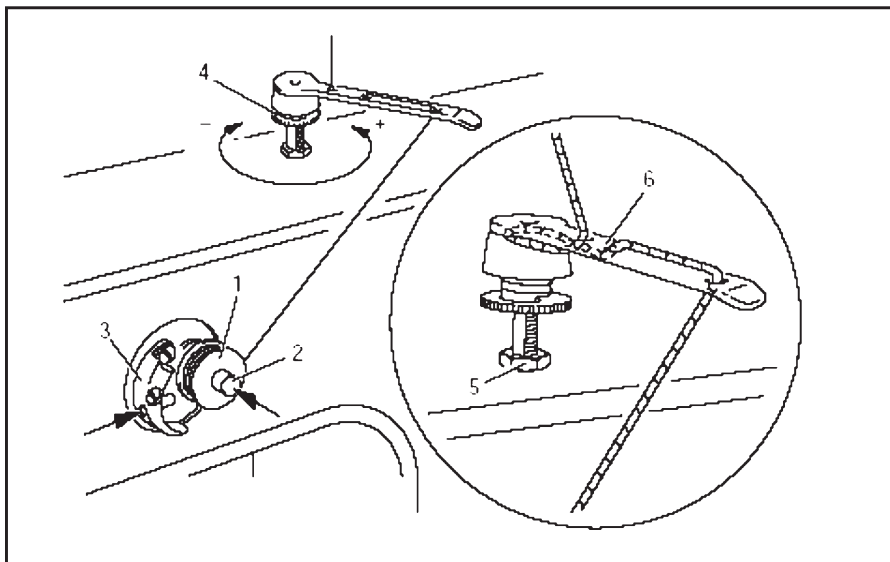

7.04

取出/装入梭壳

Removing/Inserting the bobbin case



关闭机器电源！ 有被机器意外地起动伤害的危险！
Switch the machine off! Danger of injury if the machine is started accidentally !

取出梭壳:

Removing the bobbin case:

- 打开柱式底板帽。
- 抬起梭门闩1并取出梭壳2。
- Open the post cap.
- Raise latch 1 and remove bobbin case 2.

装入梭壳:

Inserting bobbin case:

- 装入梭壳2。
- 关闭梭门闩并重新盖上柱式底板帽。
- Insert bobbin case 2.
- Close the latch and close the post



对9640机型的操作如图所示。
9640 is shown in Fig.

7.05

梭壳穿线/调节梭心线的张力

- 将梭心放入梭壳 1中。
- 将线穿过弹簧2下的狭槽中。
- 将线穿过凹口处。
- 通过转动螺钉3调节梭心线张力。
- Insert the bobbin into the bobbin case 1.
- Pass the thread through the slot under spring 2.
- Pass the thread through the notch.
- Adjust the thread tension by turning screw 3.



当拉线时，梭心必须朝箭头方向旋转。
When the thread is pulled, the bobbin must rotate in the direction of the arrow.

机器准备 Preparation

7.06 在9630机型上穿针线并调节针线张力 Threading the needle thread and regulating its tension on model 9630.



关闭机器电源！

有被机器意外地起动伤害的危险！

Switch the machine off!

Danger of injury if the machine is started accidentally!



- 向上摆动护眼罩1。
- 如图所示穿针线。
- 在9630机型上，针线是从左向右穿。
- 通过转动滚花螺栓1调节针线的张力。
- Tilt up the eye guard 1.
- Thread the needle thread as shown in Fig.
- On model 9630 from left to the right.
- Adjust the needle thread tension by turning milled screw 1.

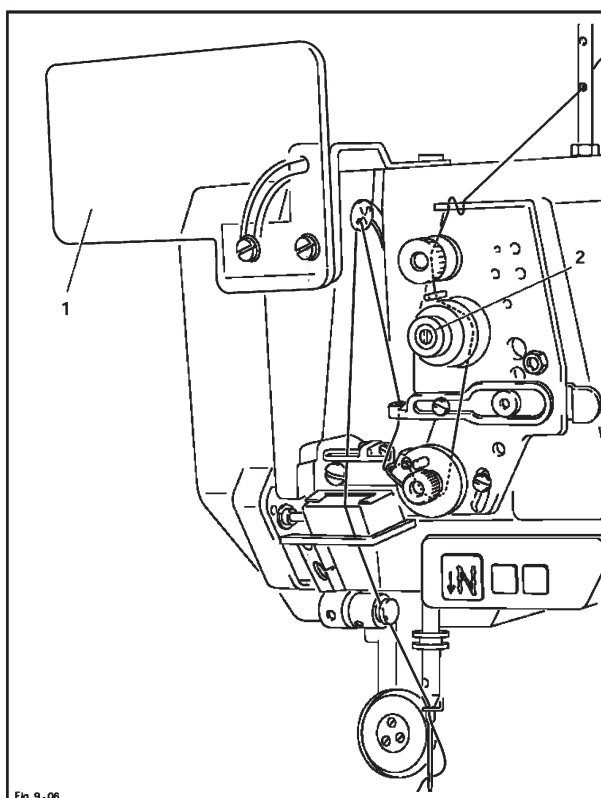

7.07 在9640机型上穿针线并调节针线张力

Threading the needle thread and regulating its tension on model 9640



关闭机器电源！

有被机器意外地起动伤害的危险！

Switch the machine off!

Danger of injury if the machine is started accidentally!

- 向上摆动护眼罩**1**。
- 如图所示穿两个针线。
- 在左边的机针上，针线是从右向左穿；而在右边的机针上，针线是从左向右穿。
- 通过转动滚花螺栓**1**调节针线的张力。
- Tilt up the eye guard **1**.
- Thread both needle threads as shown in Fig.
- The left needle is threaded from right to the left, and the right needle from the left to right.
- Adjust the needle thread tension by turning milled screw **1**.

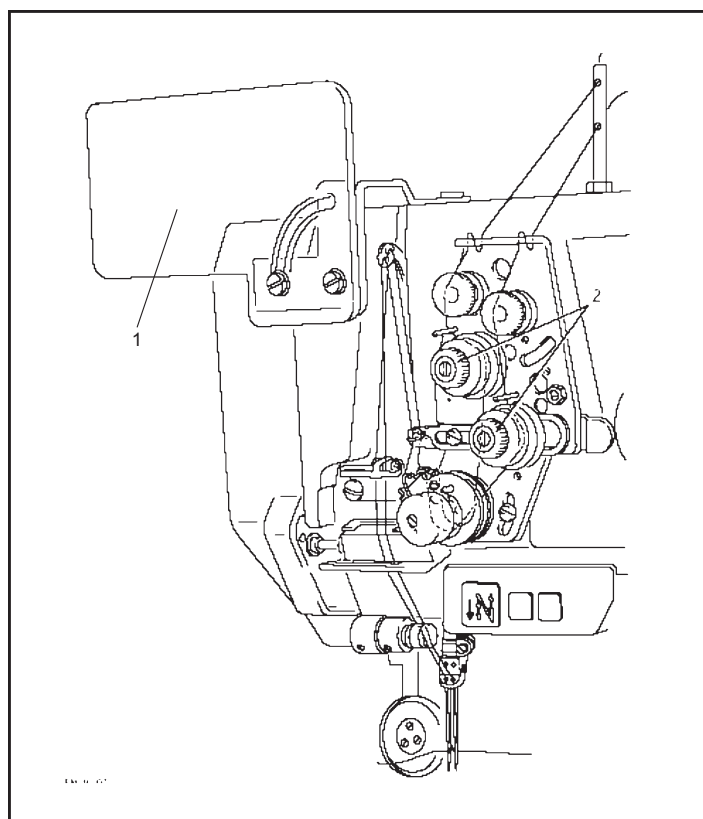

机器准备 Preparation

7.08

设置线迹长度

Setting the stitch length



- 轻触屏幕上键1解锁屏幕。
- 轻触屏幕上键2增加下送料针距, 键3减少下送料针距。
- 轻触屏幕上键4增加上送料针距, 键5减少上送料针距。
- 注意: 上送料针距和下送料针距必须相等。
- Touch key 1 on screen lightly then screen unlocked.
- Touch key 2 (key 3) on screen lightly to increasing (decreasing) nether stitch length.
- Touch key 4 (key 5) on screen lightly to increasing (decreasing) upper stitch length.
- Note:nether stitch length must equals upper stitch length.



维护与保养 Care and Maintenance

8 维护与保养 Care and Maintenance

清洁	每天, 如果持续运行时, 每天多次
油量检查 (线润滑/旋梭润滑)	每天, 开机之前
给旋梭加油	每天, 开机之前
伞齿轮副润滑	每年一次
检查/调节空气压力	每天, 开机之前
清洁空气滤清器/润滑器的过滤网	在需要时

Clean	daily, more frequently if in continuous operation
Oil level (thread lubrication/hook lubrication)	daily, before use
Oil the hook	daily, before use
Lubricate the bevel gears	once a year
Check/adjust air pressure	daily, before use
Clean air filter of air filter/lubricator	when required



上述的保养间隔是根据每天单班作业的平均机器运行时间设定的。在机器运行时间增加的情况下, 建议缩短保养间隔。

These maintenance intervals are calculated for the average running time of a single shift operation. If the machine is operated more than this, shorter intervals are recommended.

8.01 清洁 Cleaning

每天清洁旋梭, 旋梭 和 齿轮**3**, 如果持续运行时, 每天清洁多次。
Clean the hook, hook compartment and toothed wheel **3** every day, several times if in continuous use



关闭机器电源!
有被机器意外地起动伤害的危险!

Switch the machine off!
Danger of injury if the machine is started accidentally!

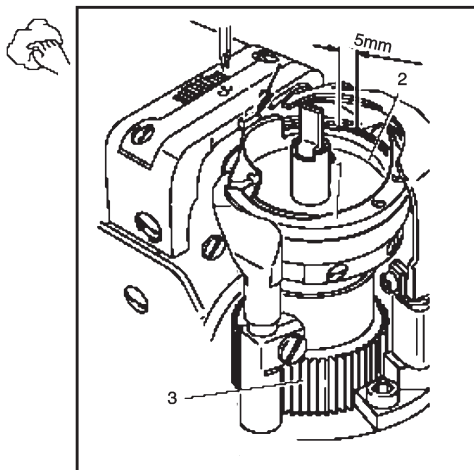

- 将针杆 到最高位置。
- 打开柱式底板帽，取出梭壳和梭心
- 拧开内梭头舌1的螺钉。
- 转动手轮，直到梭壳2尖端进入旋梭的导槽内大约5mm。
- 取出梭壳2。
- 用石蜡清洁旋梭槽。
- 当放入梭壳2时，要确信梭壳2的凸出鼻端部分啮合入针板的凹槽中。
- 拧紧内梭头舌1的螺钉并关闭底板帽。
- Bring the needle bar to its highest position.
- Open the post cap and remove the bobbin case cap and the bobbin.
- Unscrew hook gib 1.
- Turn the hand wheel until the point of bobbin case 2 penetrates into the groove of the hook race approx. 5mm.
- Remove bobbin case 2.
- Clean th hook race with paraffin.
- When inserting the bobbin case 2, ensure that the horn of the bobbin case 2 engages in the groove of the needle plate.
- Screw hook gib 1 back on and close the post cap.

8.02 给旋梭加油 Oiling the hook



关闭机器电源！
有被机器意外地起动伤害的危险！

Switch the machine off!

Danger of injury if the machine is started accidentally!

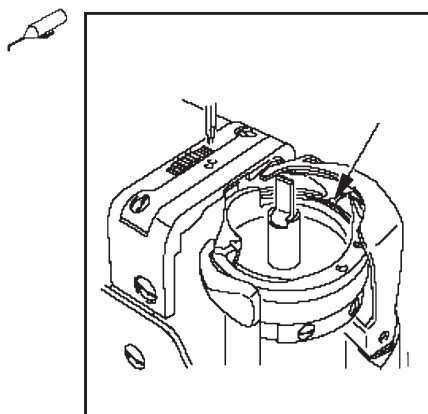

- 每天注1-2滴油到内梭头舌的孔1中。
- 在机器试车前及在长期停机后，注入几滴油到旋梭的槽中（参见箭头所示）。
- Pour 1-2 drops of oil into hole 1 of the hook gib daily.
- Before commissioning the machine, and after long periods out of operation, pour a few drops of oil into the hook race (see arrow).

8.03 旋梭润滑油盒 Oil bowl for hook lubrication

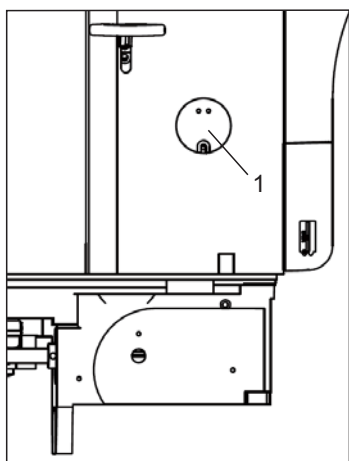

在每次开机前检查油量。必须始终保持油盒1中有油。

Check the oil level before each use.
There must always be oil in reservoir 1.

如果需要可通过加油孔加油。
If required refill oil through hole.



只允许使用在40℃ 时平均粘度为
22.0 mm²/s和在15℃时密度为
0.865 g/cm³ 的润滑油。



Use only oil with a mean viscosity of
22.0mm²/s at 40℃ and a density of
0.865g/cm³ at 15℃.

8.04 给线润滑系统的油盒加油 Filling the oil reservoir of the thread lubrication unit



在每次开机前检查油量。
必须保持油盒1中始终有油。

Control the oil level before each use.

There must always be oil in the reservoir 1.

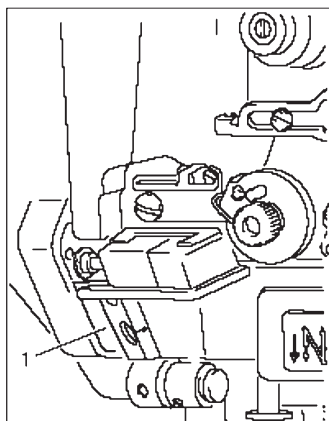

- 如果需要可通过加油孔加油到标记处。
- If necessary, fill oil up to mark through hole.



我们推荐使用线润滑油。
We recommend thread lubricating oil .

8.05

给伞齿轮副润滑

Lubricating the bevel gears



关闭机器电源！
有被机器意外地起动伤害的危险！
Switch the machine off!

Danger of injury if the machine is started accidentally!

- 所有伞齿轮副每年必须加一次新油脂。
- 向后翻转机头到支承件上。
- All bevel gears must be supplied with new grease once a year.
- Tilt the sewing head back onto the support.



如图显示出 9640机型的伞齿轮副。

Fig. shows the bevel gears of the 9640.

- 涂油脂到齿轮的全部齿侧面（见箭头所示）。
- 在将机头放回垂直位置时，先向后按翻转保险1，并用双手将机头放回垂直位置。
- Apply grease to all the tooth flanks and the rack (see arrows).
- To set the sewing head upright, press tilt lock 1 backwards and set the sewing head upright using both hands.



必须用双手将机头放回垂直位置
有在机头和抬板之间被挤伤的危险！

Use both hands to set the sewing head upright!

Danger of crushing between the sewing head and the table top!



我们推荐使用滴点大约为150℃含钠油脂。

We recommend sodium grease with a dripping point of approx.150C.

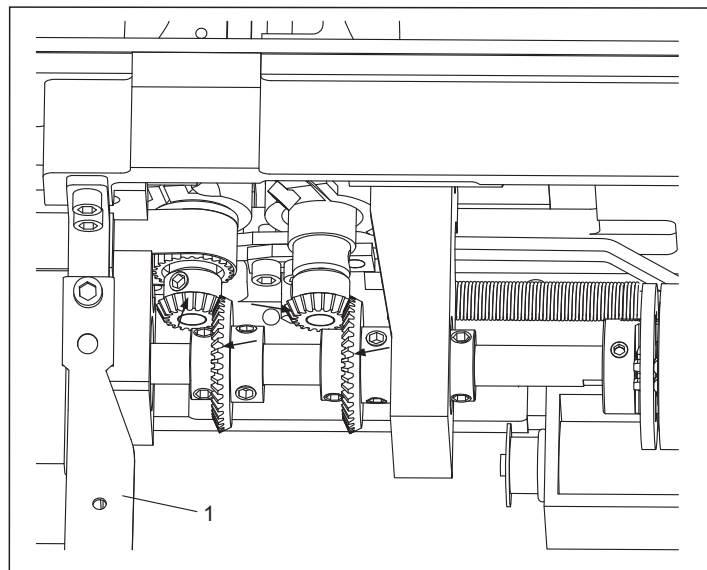

9 调整 Adjustment



除非有特别说明,否则在所有调整工作中必须将机器从电源和压缩空气供给系统上断开!

有被机器意外地起动伤害的危险!

Unless stated otherwise, during all adjustment work the machine must be disconnected from electric and pneumatic power supply!

Danger of injury if the machine is started accidentally!

9.01 对调整工作的提示

Notes on adjustment

- 本章中所述的所有调整工作都是针对全部安装完毕的机器。并且只允许由受过相应培训的专业人员来完成。
- 那些在检查和调整工作中需要拆下并重新装上的机器盖板在文章中将不再提及。
- 后续章节的顺序按照机器进行全部调整的逻辑工作顺序排列。如果仅是有目的地完成某些单项的工作步骤,则要注意其前、后章节。
- 写在括号 () 内的螺钉、螺母是用来固定机器的零部件,它们必须在调整工作之前松开,并在调整工作之后再重新拧紧。
- All following adjustment are based on a fully assembled machine and may only be carried out by expert staff trained for this purpose.
- Machine covers, which have to be removed and replaced to carry out checks and adjustments, are not mentioned in the text.
- The order of the following chapters corresponds to the most logical work sequence for machines which have to be completely adjusted. If only specific individual work steps are carried out, both the preceding and following chapters must be observed.
- Screws, nuts indicated in brackets () are fastenings for machine parts, which must be loosened before adjustment and tightened again afterwards.

9.02 工具、量规和其它辅助材料

Tools, gauges and other accessories

- 1 套头部宽度2至10 mm的螺丝刀
- 1 套开口尺寸7 至 13 mm的开口扳手。
- 1 套1.5 至 6 mm 的内六角螺钉扳手。
- 1 个夹持工具。
- 1 把金属尺子。
- 1 个量规。
- 缝纫线和试缝材料。
- 1 set of screwdrivers with blade widths from 2 to 10 mm
- 1 set of open ended wrenches with opening sizes from 7 to 13 mm
- 1 set of allen keys from 1.5 to 6mm
- 1 clamp
- 1 metal ruler
- 1 gauge
- Sewing thread and test material

调整 Adjustment

9.03 调整基础机器 Adjusting the basic machine

9.03.01 在9630机型上从缝纫方向上看机针的位置 Needle position in sewing direction on the 9630

规则

当将线迹长度设置到最小值，从向缝纫方向看，机针应该位于针板上针孔的中心。

Requirement

With the stitch length set at its minimum, the needle should be positioned in the centre of the needle hole, as seen in the direction of sewing.



- 设置到最小的线迹长度。
- 按照规则调整针杆（螺钉1）。
- Set the minimum stitch length.
- Adjust needle bar (screw 1) according to the Requirement.

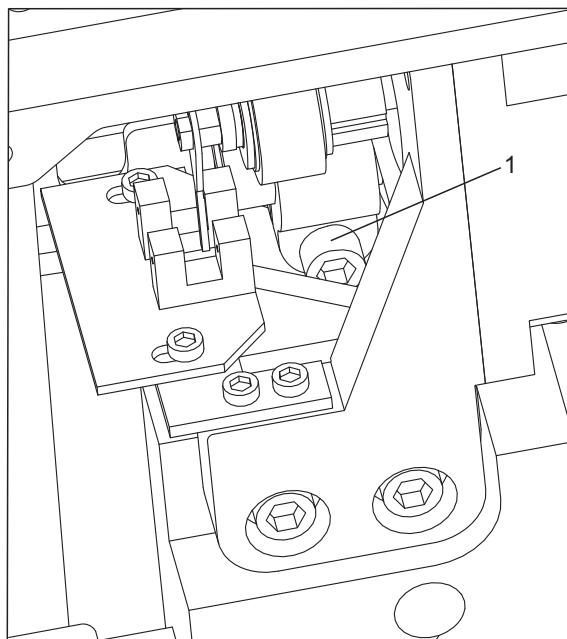

9.03.02 在9640机型上从缝纫方向看机针的位置 Needle position in sewing direction on the 9620

规则
从缝纫方向看，机针应该位于针板上针孔的中心。

Requirement
The needle should be positioned in the centre of the needle hole as seen in the direction of sewing.

- 
- 按照规则调整针杆（螺钉1和2）。
 - Adjust needle bar (screws 1 and 2) according to the Requirement.

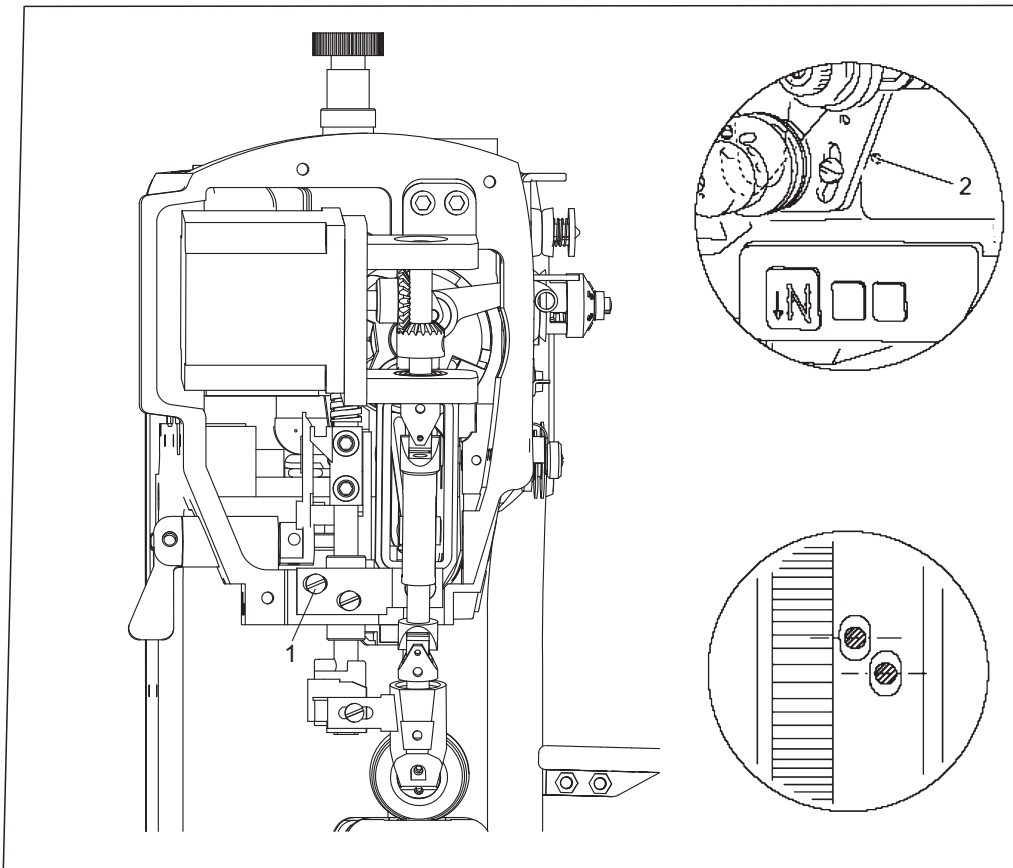

调整 Adjustment

9.03.03

初步调整针的高度

Preliminary adjustment of the needle height

规则

当针杆位于上死点时，在针尖到针板之间大约21 mm的距离。

Requirement

When the needle bar is at top dead centre, there must be a clearance of approx. 21mm between the needle point and the needle plate.



- 按照规则调整针杆1（螺钉2），不要转动针杆。
- Adjust needle bar 1 (screw 2). Without turning it, according to the Requirement.

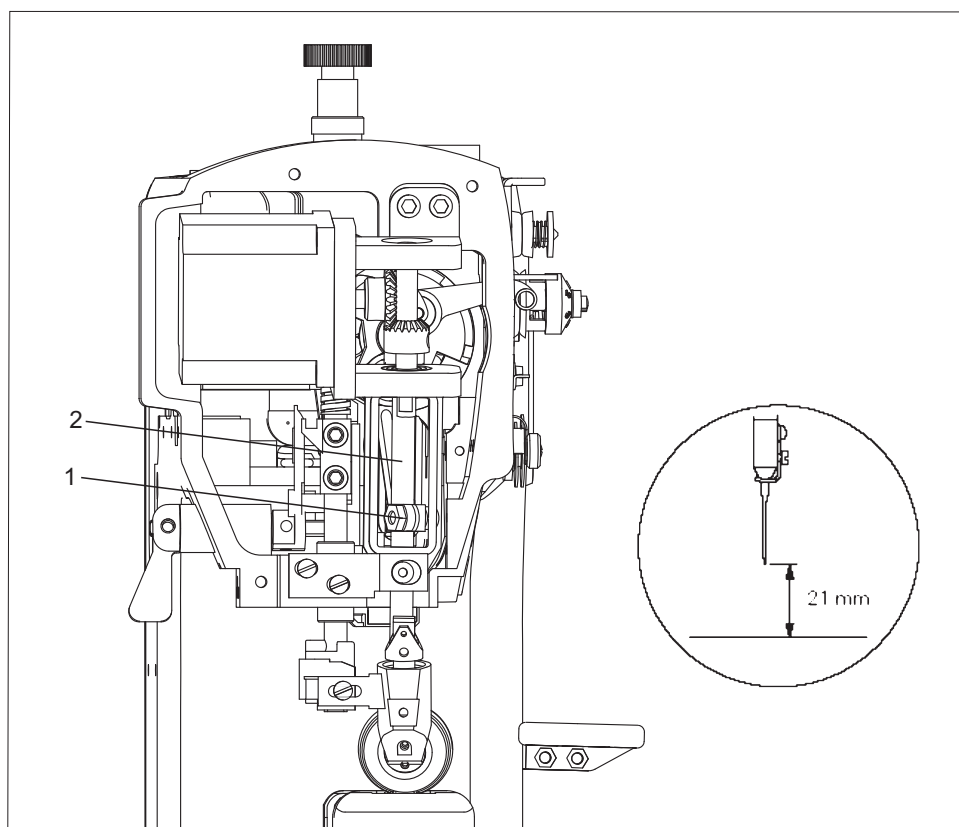

9.03.04 在 9640机型上针的上 ， 旋梭到针的距离， 针的高度和护针器 Needle rise, hook clearance, needle height and needle guard on the 9640

规则

在两个旋梭上， 将针杆置于在下死点之后上 **2.0 mm** 处：

1. 旋梭尖必须位于针的中心， 旋梭到针的距离是**0.05 至 0.1 mm**。
2. 针眼孔的上边缘必须在旋梭尖下面**0.8 至1.0 mm**。
3. 护针器**9**必须轻轻地靠着机针。

Requirement

With the needle bar positioned **2.0 mm** after bottom dead centre on both hooks

1. the hook point must be at needle centre with a hook-to-needle clearance of **0.05 to 0.1 mm**.
2. the top of the needle eye must be **0.8 to 1.0 mm** below the hook points.
3. The needle guard **9** must touch the needle lightly.

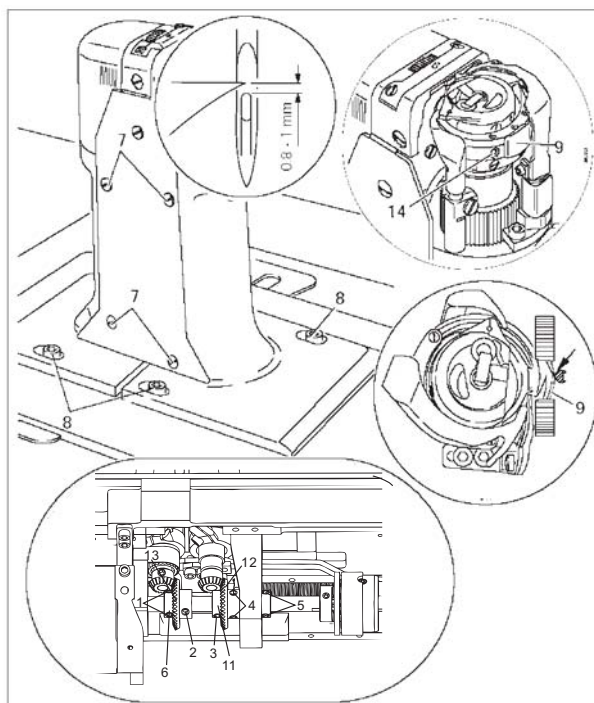

调整 Adjustment



- 拧松螺钉**1, 2, 3, 4, 5, 和7**。
- 轻微地拧松螺钉**8**。
- 将针杆置于下死点后上 **2.0 mm** 处:
- 将两个旋梭尖都调整到机针中心, 确信护针器**9**都没有造成机针偏斜。
- 根据第**2**条规则调整机针的高度。
- 按照第**1**条规则调整两个旋梭台柱并拧紧螺钉**8**。
- 拧紧螺钉**5**。
- 确信各伞齿轮副之间都有一定间隙并运转自如, 拧紧螺钉**2和4**。
- 用限位圈**6**靠住伞齿轮**13**, 拧紧螺钉**1**。
- 用限位圈**11**靠住伞齿轮**12**, 拧紧螺钉**3**。
- 在旋梭柱的两边拧紧螺钉**7**。
- 按照第**3**条规则, 在两个旋梭上调整护针器**9** (螺钉**14**) 。
- Loosen screws **1, 2, 3, 4, 5, and 7**.
- Loosen screws **8** slightly.
- Bring needle bar to **2.0 mm** past bottom dead centre.
- Set both hook points at needle centre, making sure that the needles are not deflected by needle guard **9**.
- Adjust needle height according to **Requirement 2**.
- Adjust both hook posts according to **Requirement 1** and tighten screw **8**.
- Tighten screws **5**.
- Making sure that there is some play in the bevel gear, tighten screws **2 and 4**.
- With retaining collar **6** touching bevel gear **13** tighten screws **1**.
- With retaining collar **11** touching bevel gear **12** tighten screw **3**.
- Tighten screws **7** on both sides of the post.
- Adjust needle guard **9** (screw **14**) on both hooks according to **Requirement 3**.



当更换旋梭时, 确信两个标记**15**和**16**在同一边。

When a hook is changed, make sure that the markings **15** and **16** are both on one side.

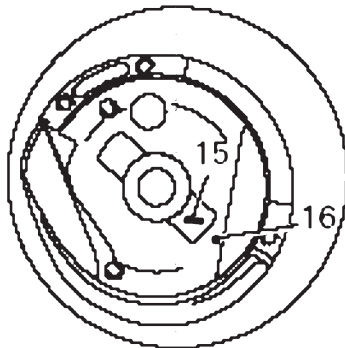

9.03.05 在9630机型上针的上 ，旋梭到针的距离，针的高度和护针器 Needle rise, hook clearance, needle height and needle guard on the 9630

规则

当设置线迹长度为“0.8”，将针杆置于在下死点之后上 2.0 mm 处:

1. 旋梭尖必须位于针的中心，旋梭到针的距离是0.05 至 0.1 mm 。
2. 针眼孔的上边缘必须在旋梭尖下面0.8 至1.0 mm。
3. 护针器6必须轻轻地靠着机针。

Requirement

With the needle bar positioned 2.0mm after bottom dead centre and the stitch length set at “0.8”:

1. the hook point must be at needle centre with a hook-to-needle clearance of 0.05 to 0.1mm.
2. the top of the needle eye must be 0.8 to 1.0 mm below the hook point.
3. The needle guard 6 must touch the needle lightly.

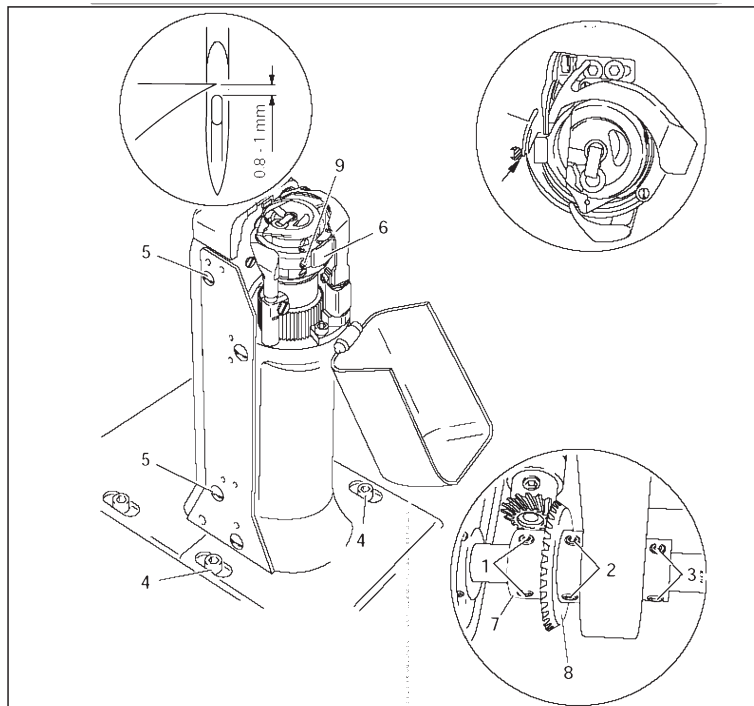

调整 Adjustment



- 设置线迹长度为 "0.8".
- 拧松螺钉1, 2, 3, 4和5。
- 将针杆置于下死点后上 2.0 mm 处:
- 将旋梭尖调整到机针中心, 确信护针器6没有造成机针偏斜。
- 按照第2条规则调整机针的高度。
- 按照第1条规则调整旋梭台柱并拧紧螺钉4。
- 确信伞齿轮副之间有一定间隙并运转自如, 拧紧螺钉2。
- 用限位圈7靠住伞齿轮8, 拧紧螺钉1。
- 按照第3条规则调整护针器6 (螺钉9)。
- Set stitch length at "0.8".
- Loosen screw 1, 2, 3, 4 and 5.
- Bring needle bar to 2.0 mm past bottom dead centre.
- Set hook point at needle centre, making sure that the needle is not deflected by needle guard 6.
- Adjust needle height according to Requirement 2.
- Adjust hook post according to Requirement 1 and tighten screw 4.
- Making sure that there is some play in the bevel gear, tighten screws 2.
- With retaining collar 7 touching bevel gear 8 tighten screws 1.
- Adjust needle guard 6 (screw 9) according to Requirement 3.



当更换旋梭时, 确信两个标记10和11在同一边。

When the hook is changed, make sure that the markings 10 and 11 are both on one side.

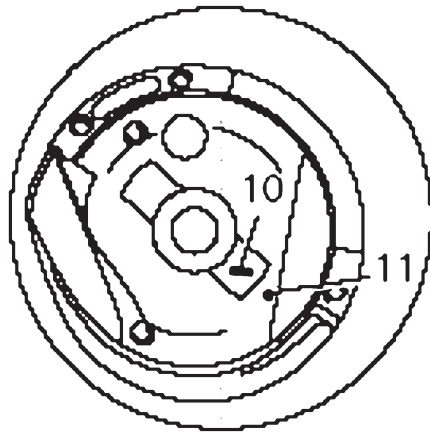

9.03.06 在9640机型上从垂直于缝纫方向看机针的位置 Needle position crosswise to sewing direction on the 9640

规则

当从垂直于缝纫方向看时，机针都必须位于针板的针孔中心。

Requirement

As seen crosswise to the sewing direction, the needles must penetrate in the centre of their needle holes.



- 按照规则通过移动支承板1（螺栓2在柱式底板的两边）来调整。
- Shift bearing plate 1 (screws 2, on both sides of the post) according to the Requirement.

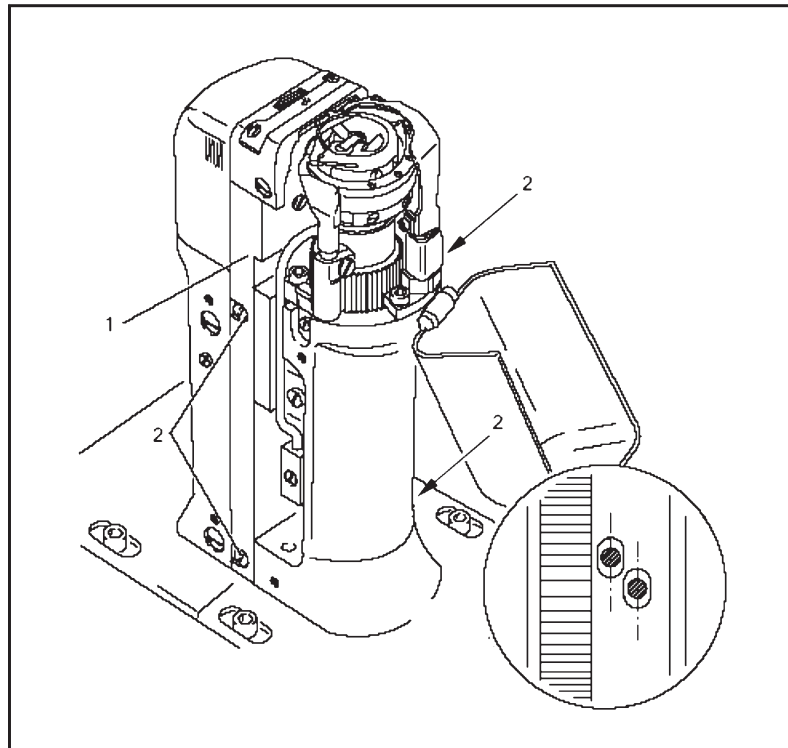

调整 Adjustment

9.03.07 在 9630机型上从垂直于缝纫方向看机针的位置 Needle position crosswise to sewing direction on the 9630

规则
当从垂直于缝纫方向看时，机针必须位于针板的针孔中心。

Requirement
As seen crosswise to the sewing direction, the needle must penetrate in the centre of the needle hole.



- 按照规则通过调整进给轮台柱1（螺栓2、3和4）来进行调整。
- Adjust feed wheel post 1 (screws 2, 3 and 4) according to the Requirement.

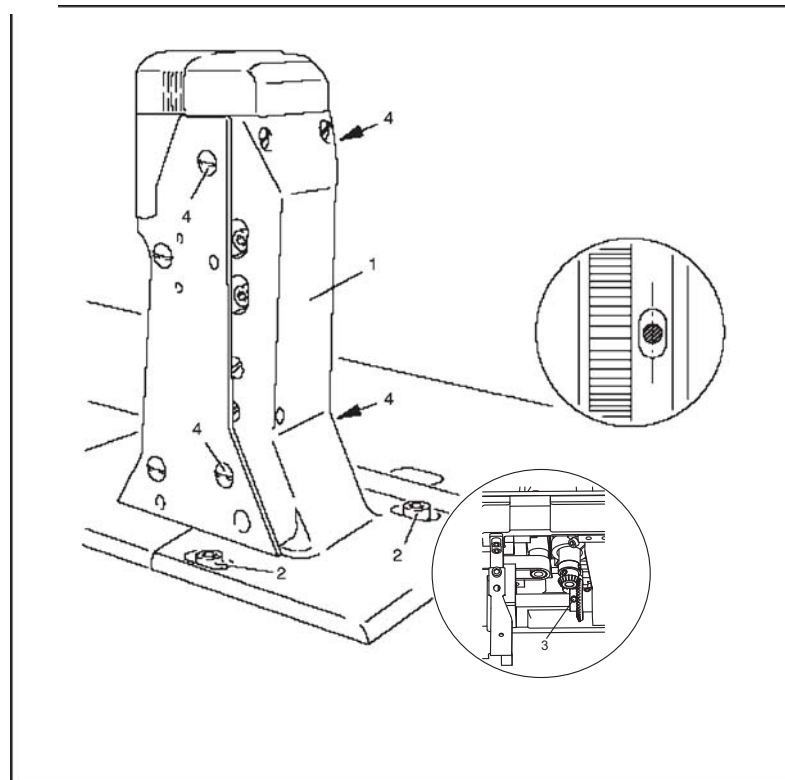

9.03.08 开梭器的高度和行程 Height and stroke of the bobbin case opener

规则

1. 开梭器**1**和梭壳架**3**的上边缘应该处于同一水平面。
2. 当开梭器**1**使梭壳偏转到其最远点时，梭壳的凸出鼻端部分应该距离针板凹槽的后边缘**0.3 至 0.5 mm**。

Requirement

1. The top edges of the bobbin case opener **1** and bobbin case **3** should be on one level.
2. when the bobbin case opener **1** has deflected the bobbin case to its furthest point, the catch of the bobbin case should be from **0.3 to 0.5 mm** from the back edge of the needle plate recess.



- 按照第**1**条规则调整开梭器**1**（螺钉**2**）。
- 旋转手轮直到开梭器使梭壳偏转到其最远点。
- 按照第**2**条规则调整开梭器**1**（螺钉**2**）。
- Adjust bobbin case opener **1** (screw **2**) in accordance with **Requirement 1**.
- Turn the balance wheel until the bobbin case opener has deflected the bobbin case to its furthest point.
- Adjust bobbin case opener **1** (screw **2**) in accordance with **Requirement 2**.

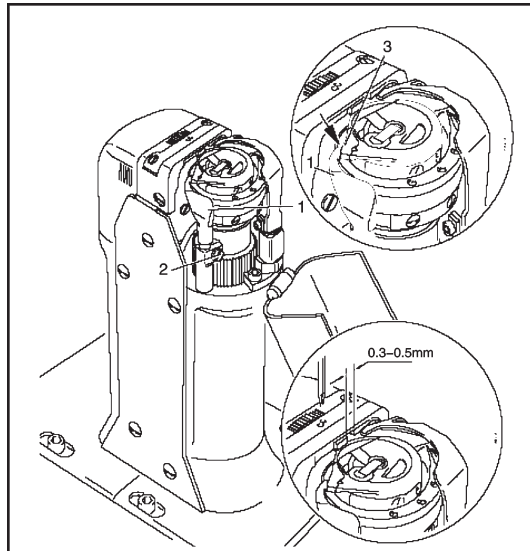

在 9640 机型上，在右边的柱台上必须重复进行上述调整工作。
根据所使用的缝纫线粗细，允许对第**2**条规则的调整做出改变。

On the 9640 these adjustments must be repeated on the right post.
Depending on the thread size, a variation of the setting in Requirement **2** is permitted.

调整 Adjustment

9.03.09 在9640机型上进给轮高度的调整 Height of the feed wheel on the 9640

规则

1. 当在进给轮4上施加压力时，它应凸出针板平面一个齿高（约**0.8 mm**）。
2. 当没有向进给轮4上施加压力时，其在垂直方向上应有**0.3 mm**的间隙。

Requirement

1. when pressure is applied to the feed wheel 4, it should protrude from the needle plate by tooth height (approx. **0.8 mm**).
2. when no pressure is applied to the feed wheel 4, it should have a vertical play of approx. **0.3 mm**.



- 向外摆动滚轮压脚。
- 拧松螺钉1和2（每一种螺钉有两个）。
- 按照第1条规则调整驱动轮3，注意驱动轮3和进给轮4的齿要相互正确地啮合。
- 拧紧螺钉1。
- 按照第2条规则调整导向件5并拧紧螺钉2。
- Swing out the roller presser
- Loosen screws 1 and 2 (two screws each).
- Adjust drive wheel 3 according to **Requirement 1**, taking care to see that the teeth of drive wheel 3 and feed wheel 4 lock into each other properly.
- Tighten screws 1.
- Adjust guide 5 according to **Requirement 2** and tighten screws 2.

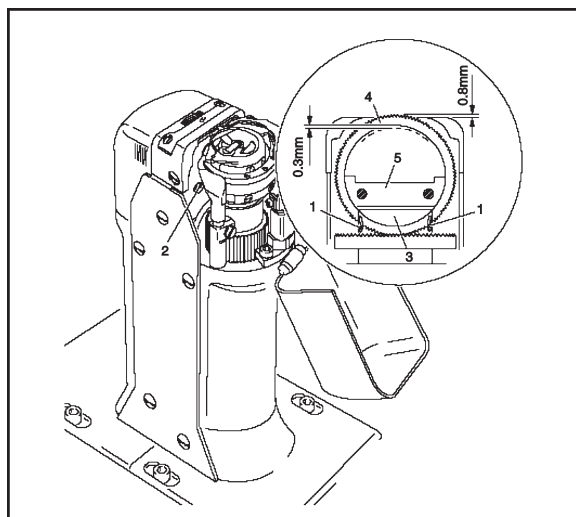

9.03.10

在9630机型上进给轮高度的调整

Height of the feed wheel on the 9630、9630S

规则
进给轮应凸出针板平面一个齿高（约**0.8 mm**）。

Requirement

Feed wheel should protrude from the needle plate by tooth height (approx. **0.8 mm**).



- 向外摆动滚轮压脚。
- 拧松螺钉**1**。
- 按照规则调整偏心销**3**（通过孔**2**容易拧动紧固螺钉）。
- 拧紧螺钉**1**。
- Swing out the roller presser
- Loosen screws **1**.
- Adjust eccentric **3** (fastening screw accessible through hole **2**) according.
- Tighten screws **1**.

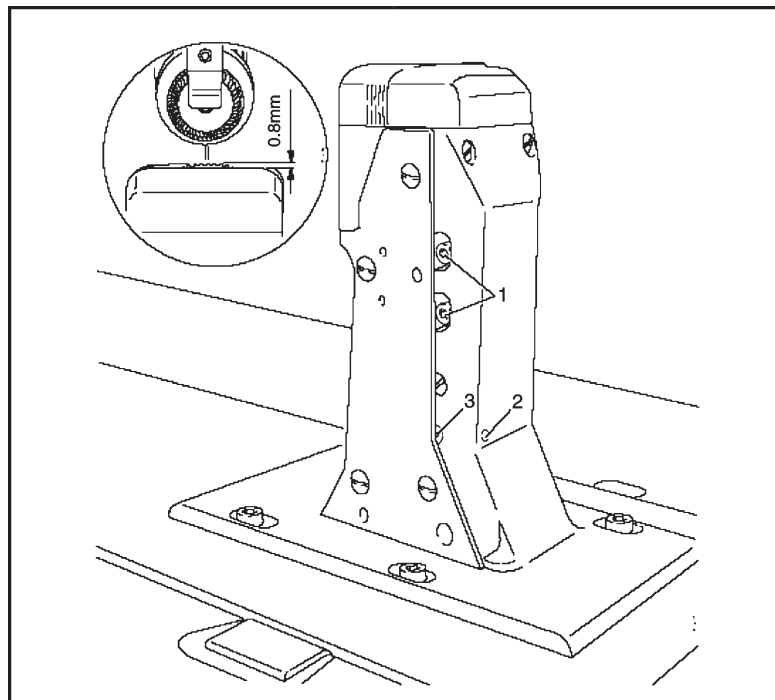

调整 Adjustment

9.03.11 滚轮压脚和进给轮之间的距离 Roller and feed wheel

规则

当压脚扳手抬起时，在滚轮压脚和进给轮之间的距离必须是7 mm。

Requirement

When the presser bar lifter is raised, the clearance between the roller presser and the feed wheel must be 7 mm.



- 抬起压脚扳手。
- 按照规则调整压脚杆1（螺钉 2）。确保滚轮压脚与进给轮平行。
- Raise the presser bar lifter.
- Adjust the presser bar 1 (screws 2) according to the **Requirement**. Make sure that the roller presser is parallel to the feed wheel.

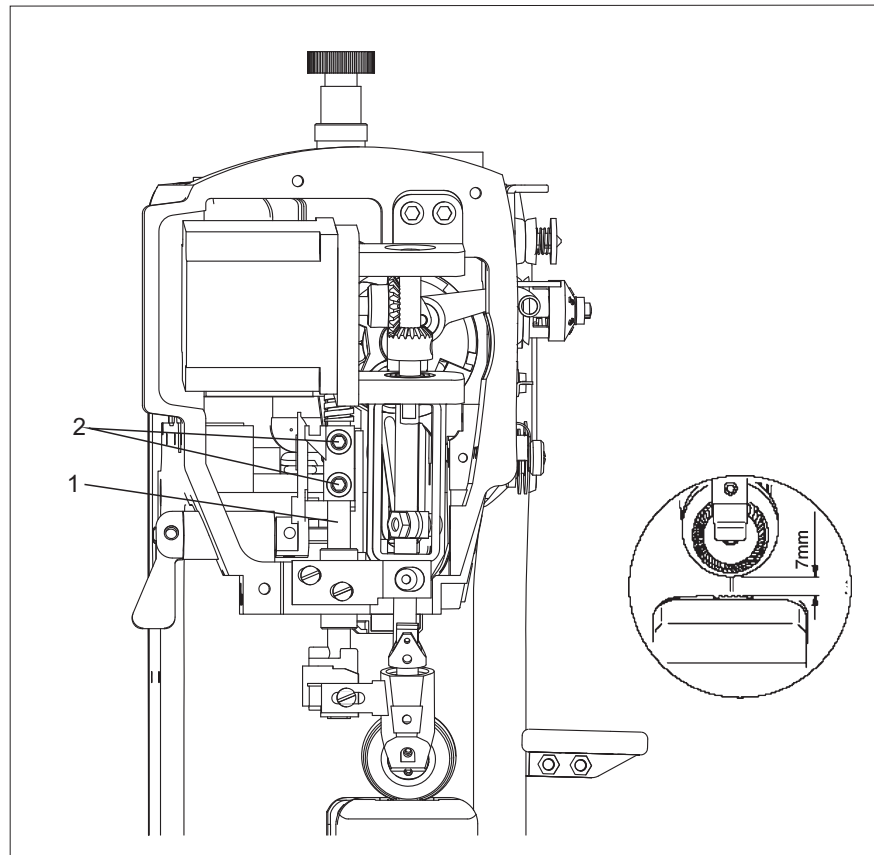

9.03.12 滚轮压脚调整 Roller presser

规则

当滚轮压脚1与进给轮5接触时，它必须满足：

1. 从缝纫方向看，与进给轮5平行。
2. 从垂直于缝纫方向看，位于针的中心（在 9640机型上位于左针的心）。
3. 从垂直于缝纫方向看，要尽可能地靠近针（在 9640机型上要尽可能地靠近左针）。

Requirement

When the roller presser 1 is touching the feed wheel 5 it must:

1. be parallel to feed wheel 5, as seen in the direction of sewing.
2. be in the centre of the needle (on model 9620 the left needle), as seen in the direction of sewing.
3. be as near as possible to the needle (on model 9640 the left needle), as seen crosswise to the direction of sewing.



- 抬起滚轮压脚。
- 在以后的调整中要始终遵守第1条规则。
- 按照第2条规则调整滚轮压脚1（螺钉2）。
- 降下滚轮压脚1，靠在进给轮5上。
- 按照第3条规则调整滚轮压脚支架3（螺钉4）。
- Raise the roller presser.
- Always observe **Requirement 1** for subsequent adjustments.
- Adjust roller presser 1 (screw 2) according to **Requirement 2**.
- Lower roller presser 1 to rest on feed wheel 5.
- Adjust roller presser bracket 3 (screw 4) according to **Requirement 3**.

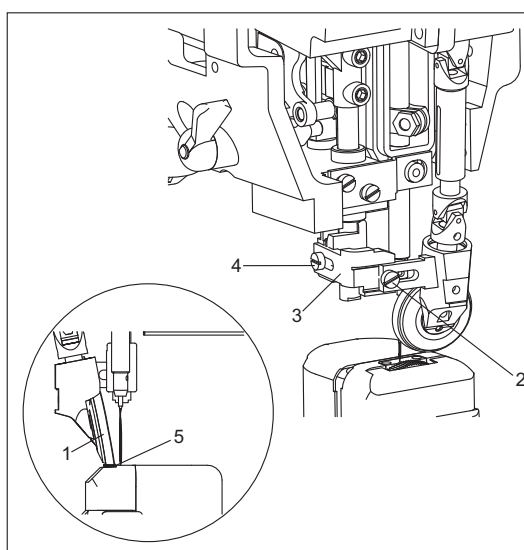

当缝纫缝式为曲率半径很小的曲线时，滚轮压脚必须向操作者方向移动一点。

When sewing very tight curves, the roller presser 1 must be moved a little towards the operator.

调整 Adjustment

9.03.13 正倒缝重合度调整 Adjusting the contact ratio of forward-back swing

规则

在任何线迹长度下，顺缝最后一针与倒缝第一针在位置上必须重合。

Requirement

No matter in which stitch length, position of last forward swing must coincide with first back swing.



- 打开电控后按住屏幕中间“M”键直至出现密码输入界面并输入密码“6666”。
- 在“机器调整目录”界面选择“主轴零点调整”，转动手轮1将针杆2至最高点，按“OK”键。
- 选择“摆针原点调整”，踩一次踏板，电机轴3槽面垂直向上表明电机到达原点，按“+”键至显示值为23，注意不要按“OK”键！
- 关闭电控，调节偏心轴4至轴上逆时针第一颗螺钉5对准电机轴3槽面，按规则锁紧螺钉。
- 再次开机按第一步操作至“机器调整目录”界面，选择“输入检测”，转换到“N10”后转动手轮1直至界面显示“000”“000”，按“OK”键保存。
- Switch on electric control, typing “6666” in the password input interface which appears after press on “M” on the screen about 3S.
- Touching “spindle origin adjusting” options under “machine adjustment directory”, rotate balance wheel until the needle bar is at its highest position, press “OK” to save.
- Selecting “pin-cycloid origin adjusting”, pedal once, the groove on axis will face up vertical, that indicate motor reaches the origin, then press “+” key until number shown is 23. Don’t touch “OK”!
- Switch off the electric control, adjust the eccentric shaft till the counterclockwise first screw on the shaft align the groove face on the motor shaft, tighten screw according to the requirement.
- Switch on the electric control again and operate according to the first step till “machine adjustment directory” display, select “input detection”, switch to “N10”, then rotate balance wheel until the interface displays “000” “000” and press “OK” to save.

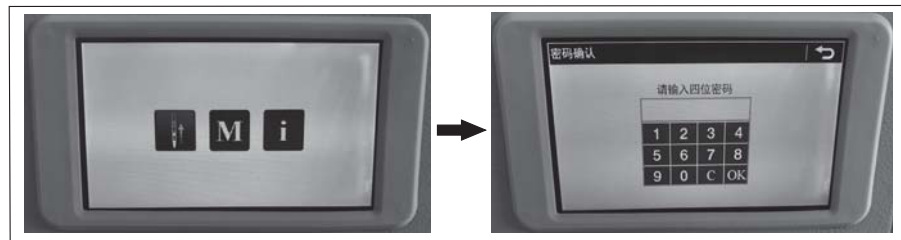

调整 Adjustment

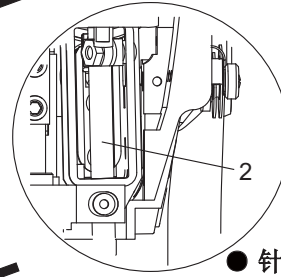
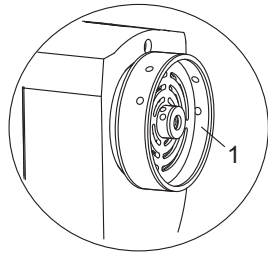
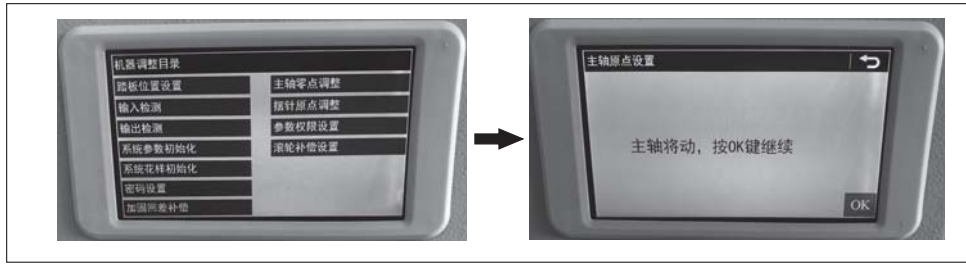

- 针杆 到最高点。
- needle bar arrives its highest point.

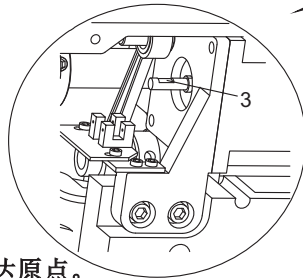

- 表明电机到达原点。
- Indicate motor reaches the origin.

- 按“OK”键后按“+”键直至显示 字为23。
- Touch “OK” then press “+” until the number shown is 23.

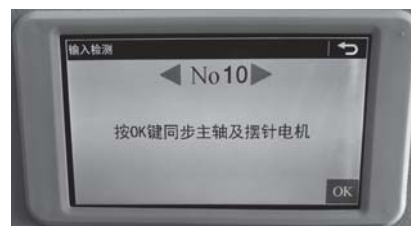
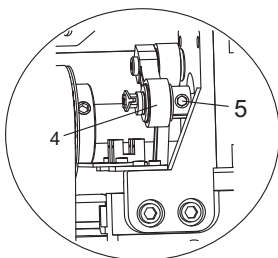

- 按规则锁紧逆时针一颗螺钉, 按操作面板中的返回键, 注意不要按“OK”键。
- Tightening first counterclockwise screw according to the requirement, touch “return”, don't touch “OK”.

调整 Adjustment

9.03.14 压料器（仅 9640机型才有） Retainer(only on 9640)

规则

压料器1必须:

1. 从缝纫方向看，应尽可能地靠近针，并且
2. 从垂直于缝纫方向看，位于针的中心。
3. 当滚轮压脚下降时，在压料器1和缝料间的距离必须是**0.2 - 0.3 mm**。

Requiemnt

The retainer 1 must:

1. be as close as possible to the needle, as seen in the direction of sewing .
2. be in the centre of the needle, as seen crosswise to the direction of sewing.
3. when the roller presser is lowered, the distance between the retainer 1 and the workpiece must be **0.2-0.3 mm**.



- 按照第3条规则调整压料器器1（螺钉2）。
- 按照第1条和第2条的规则调整支架3（螺钉4）。
- Adjust retainer 1 (screw 2) according to Requirement 3.
- Adjust bracket 3 (screw 4) according to Requirement 1 and 2.

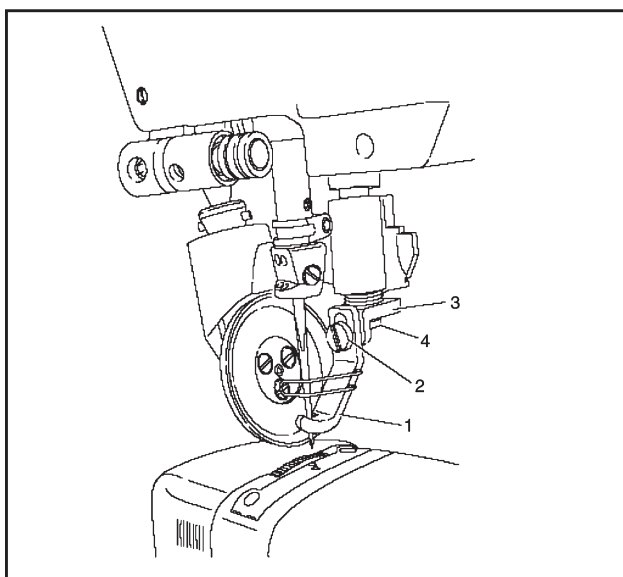

9.03.15 膝提杆 Knee lever

规则

1. 在滚轮压脚抬起前，膝提杆必须有一个微小的空程。
2. 当膝提杆被挤压到最远端时，滚轮压脚扳手必须自动地落下。
3. 膝提杆组件的杆件**5**必须与底板成大约**75°**角。

Requirement

1. before the roller presser rises, the knee lever must still have a slight play.
2. when the knee lever is raised as far as possible, the lever for the roller presser must drop automatically.
3. knee lever bar **5** must be at an angle of approx. **75°** to the bedplate.



- 按照第**3**条规则调整螺栓**1**（螺母**2**）。
- 按照第**2**条规则调整螺栓**3**（螺母**4**）。
- 按照第**3**条规则调整杆件**5**（螺栓**6**）。
- Adjust screw **1** (nut **2**) according to **Requirement 3**.
- Adjust screw **3** (nut **4**) according to **Requirement 2**.
- Set bar **5** (screws **6**) according to **Requirement 3**.

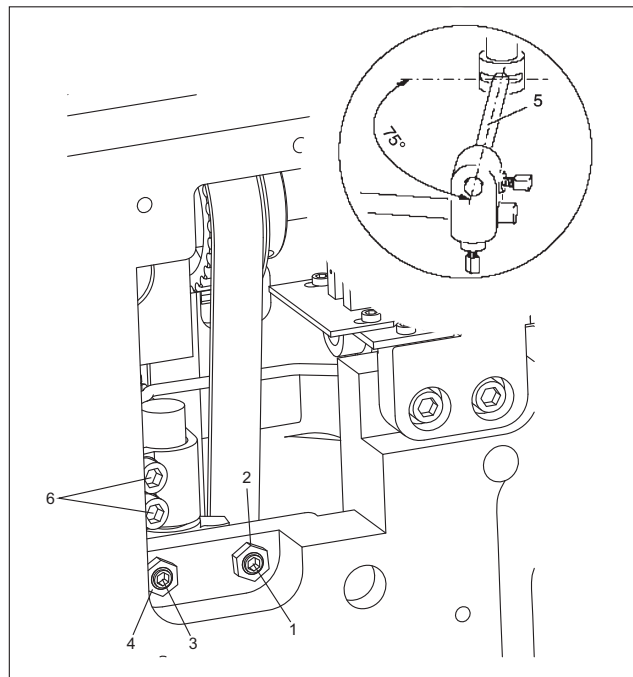

调整 Adjustment

9.03.16 针线松线调整 Needle thread tension release

规则

1. 当压脚扳手抬起时，夹线板**3**应该被挤开最少**0.5 mm**。
2. 当滚轮压脚下降时，夹线器必须完全地起作用。

Requirement

1. when the presser bar lifter is raised, the tension discs **3** should be pressed at least **0.5 mm** apart.
2. When the roller presser is lowered, the tension must be fully effective.



- 按照规则校正、调整夹线器安装板**1**和压力板**2**。
- Align tension mounting plate **1** and pressure plate **2** according to Requirement.

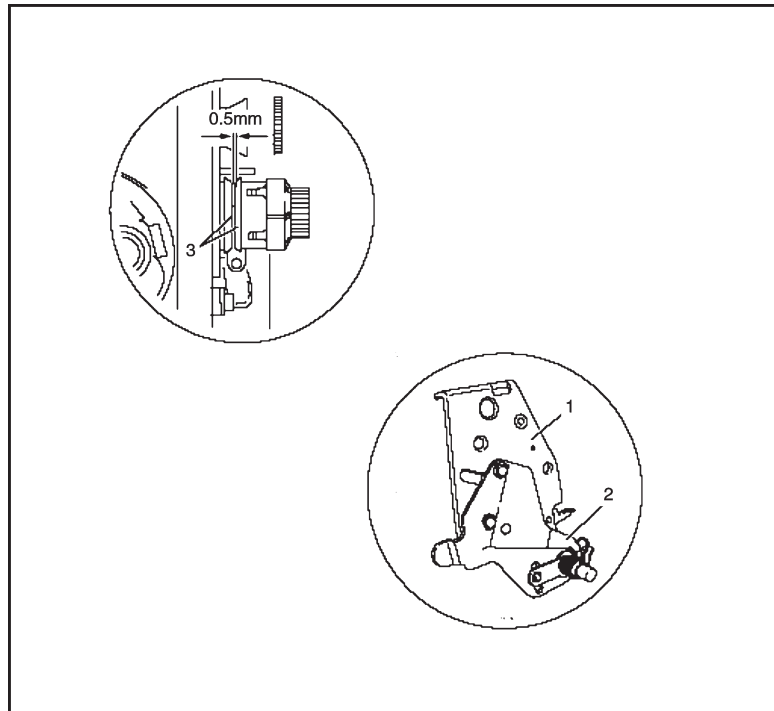

9.03.17 挑线簧调整(9630机型) Thread check spring (9630 model)

规则

1. 当针尖穿刺缝料时,挑线簧7应完成运动动作 (弹簧行程大约7 mm)。
2. 在针线绕着旋梭形成最大线环时,挑线簧7应从其支承件上轻微地上。

Requirement

1. the movement of thread check spring 7 should be completed when the needle point penetrate the fabric (spring stroke approx. 7 mm).
2. when the largest thread loop is formed while the thread is passed around the hook, the thread check spring 7 should rise slightly from its support.



- 按照第1条规则调节支承件1 (螺钉2)。
- 转动螺钉3 (螺钉4) 以调整弹簧张力。
- 按照第2条规则调整导线钩5 (螺钉6)。
- Adjust support 1 (screw 2) according to **Requirement 1**.
- Adjust the spring tension by turning screw 3 (screw 4).
- Adjust the thread regulator 5 (screw 6) according to **Requirement 2**.



由于技术原因, 可能有必要改变弹簧行程和压力使其偏离指定值。向“+”方向移动导线钩5 (螺钉6) (供线量增多); 或向“-”方向移动 (供线量减少)。
For technical reasons it may be necessary to deviate from the specified spring stroke or spring tension. Move the thread regulator 5 (screw 6) towards “+” (= more thread) or “-” (= less thread).

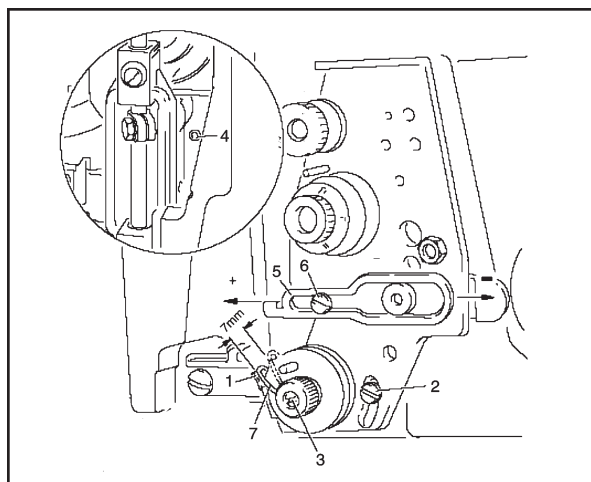

调整 Adjustment

9.03.18 挑线簧调整(9640机型) Thread check springs (9640 model)

规则

1. 当针尖穿刺缝料时,挑线簧3和6应完成其运动动作(弹簧行程大约7 mm)。
2. 在针线绕着旋梭形成最大线环时,挑线簧3和6应从其支承件1和9上轻微地上。

Requirement

1. The movement of thread check springs 3 and 6 should be completed when the needle points penetrate the fabric (spring stroke approx. 7 mm).
2. when the largest thread loop is formed while the thread is passed a round the hook, the thread check springs 3 and 6 should rise slightly from supports 1 and 9.

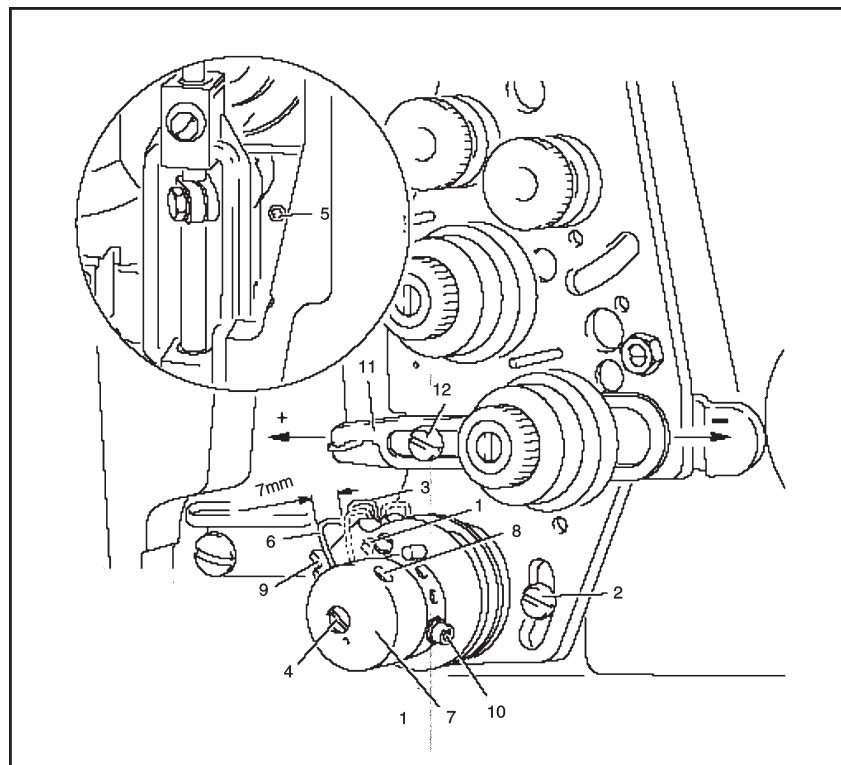



- 按照第1条规则调节支承件1（螺钉2）。
- 转动螺钉4（螺钉5）以调整挑线簧3的张力。
- 转动套筒7（螺钉8）以调整挑线簧6的张力。
- 按照第1条规则调节支承件9（螺钉2）。（如果调整范围太低，支承件9可以换一个螺钉孔安装。
- 按照第2条规则调整导线钩11（螺钉12）。
- Adjust support 1 (screw 2) according to **Requirement 1**.
- Adjust the spring tension of thread check spring 3 by turning screw 4 (screw 5).
- Adjust the spring tension of thread by checking spring 6 and 7 (screw 8).
- Adjust support 9 (screw 10) according to **Requirement 1**. (If the adjustment range is too low, support 9 can be screwed into another hole).
- Adjust the thread regulator 11 (screw 12) according to **Requirement 2**.



由于技术原因，可能有必要改变弹簧行程和压力使其偏离指定值。
向“+”方向移动调线器11（螺钉12）（供线量增加）；或向“-”方向移动（供线量减少）。

For technical reasons it may be necessary to deviate from the specified spring stroke or spring tension.

Move the thread regulator 11 (screw 12) towards “+” (=more thread) or “-” (= less thread).

调整 Adjustment

9.03.19 绕线器 Bobbin winder

规则

1. 当绕线器处于啮合状态时，绕轴必须可靠地被驱动。当绕线器处于脱离状态时，驱动轮1应不能造成摩擦轮5运动。
2. 当在梭心上所绕的线距离梭心边缘1 mm 时，绕线器应自动停止转动。

Requirement

1. when the bobbin winder is engaged, the winding spindle must be driven reliably. When the bobbin winder is disengaged, the friction wheel 5 must not be moved by drive wheel 1.
2. the bobbin winder must switch itself off, when the filled thread is about 1 mm from the edge of the bobbin.



- 按照第1条规则调整驱动轮1的位置（螺钉2）。
- 按照第2条规则调整销栓3的位置（螺钉4）。
- Position drive wheel 1 (screws 2) according to Requirement 1.
- Position bolt 3 (screw 4) according to Requirement 2.

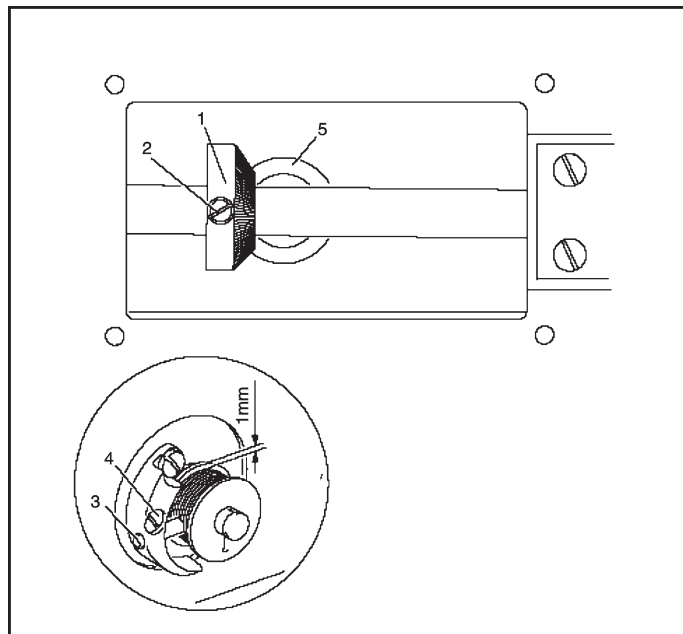

9.03.20 滚轮压脚的压力调整 Pressure of roller presser

规则
缝料必须平稳地进给。在缝料上不应有可见压痕。

Requirement
The material must be fed smoothly. No pressure marks should be visible on the material.



- 按照规则通过螺钉1来调整滚轮压脚的压力。
- Adjust roller pressure with screw 1 according to the **Requirement**.

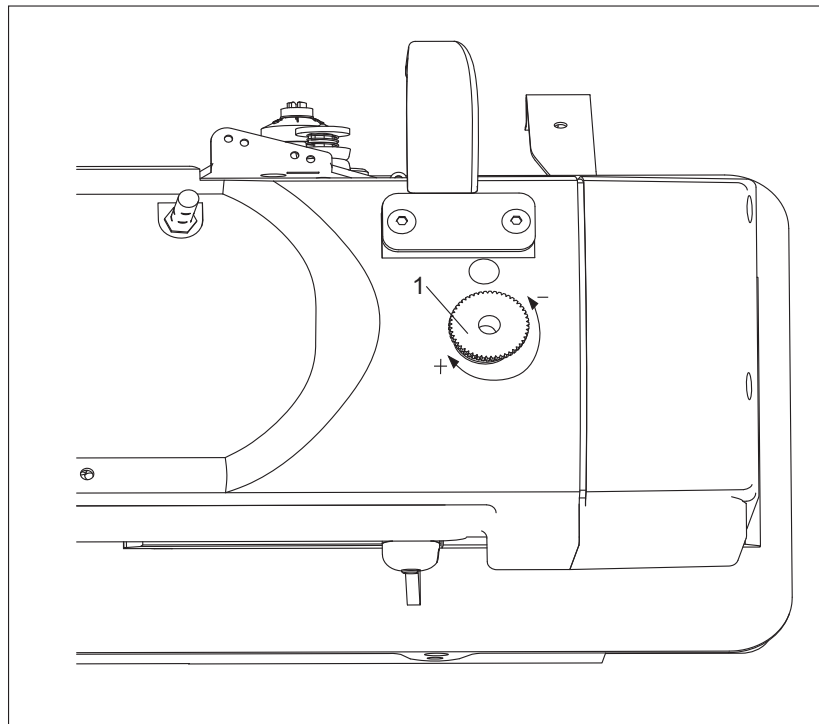

调整 Adjustment

9.03.21 润滑 Lubrication

规则
在运行**10**秒钟后，在紧挨着旋梭的纸条上形成一条细线形油迹。

Requirement
After a running time of **10 seconds** a fine line of oil should form on a strip of paper held next to the hook.



- 检查是否加了油及是否油线中有空气。
- 让机器运转**2至3**分钟。
- Check whether oil has been filled in and that there is no air in the oil lines.
- Let the machine run for **2-3 min.**

在机器运转过程中，不要将手伸到机针和旋梭区域！
有被运动的机件伤害的危险！

While the machine is running do not place hands in the needle or hook area!
Danger of injury from moving parts!

- 当机器运转时，持一长纸条挨在旋梭上并按照规则进行检查。
- 如果有必要，通过调节螺钉**1**来调整油流。
- With the machine running hold a strip of paper on the hook and check according to the **Requirement**.
- If necessary, adjust the oil flow on screw **1**.

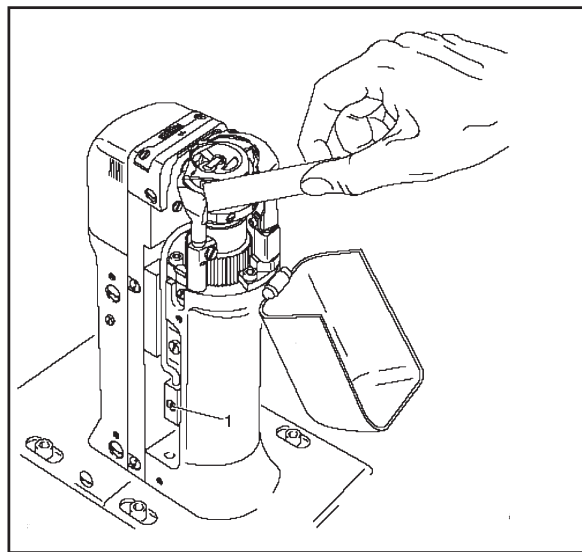

9.03.22 安全联轴器复位 Re-engage safety coupling



安全联轴器**1**是由机器制造商安置的。当发生线缠结时，安全联轴器**1**脱开以避免损坏旋梭。

下面说明如何使安全联轴器重新复位啮合。

The coupling **1** is set by the manufacturer. When the thread jams, the coupling **1** disengages in order to avoid damage to the hooks.

A description of how to engage the coupling follows.



- 去除缠结的线。
- 用螺钉**2**固定住安全联轴器**1**，转动手轮直到感觉到安全联轴器**1**突然恢复进入原位。
- Remove jammed thread.
- Hold coupling **1** with screw **2** and turn the balance wheel, until you feel coupling **1** snap back into place again.

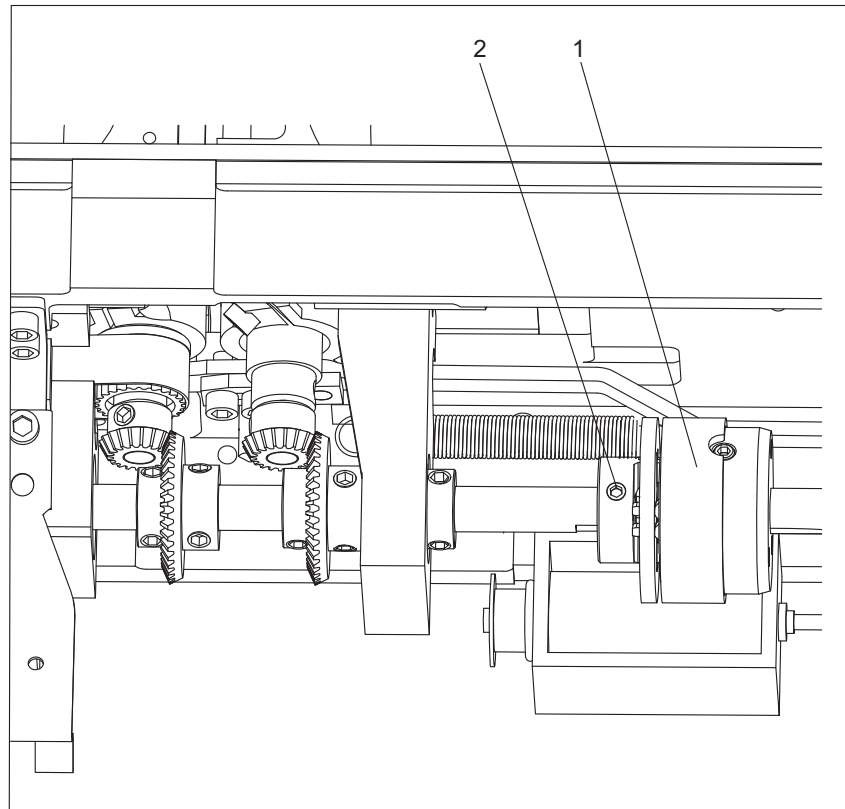

调整 Adjustment

9.04 剪线器-D的调整 Adjusting the thread trimmer -D

9.04.01 滚子杠杆的静止位置/控制凸轮的径向位置调整 Resting position of the roller lever/ radial position of the control cam

规则

1. 当剪线器在静止位置时，杠杆**5**应与活塞**6**相接触，而且滚轮杠杆的滚轮与控制凸轮**3**之间有**0.3 mm**的距离。
2. 当挑线杆在上死点时，控制凸轮**3**应该正好使滚轮杠杆**7**处于静止位置。

Requirement

1. when the thread trimmer is in resting position, lever **5** should be touching piston **6** and the roller of roller lever **7** should be **0.3 mm** away from control cam **3**.
2. when the take-up lever is at top dead centre, control cam **3** should just have placed roller lever **7** in its resting position.



- 当确信活塞**6**定位在左止点时，按照第1条规则调整电磁铁**1**（两个螺钉）。
- 按照第2条规则调整控制凸轮**3**（螺钉**4**）。
- Having made sure that piston **6** is positioned against the left stop, adjust magnet **1** (2 screws) in accordance with **Requirement 1**.
- Adjust control cam **3** (screw **4**) in accordance with **Requirement 2**.

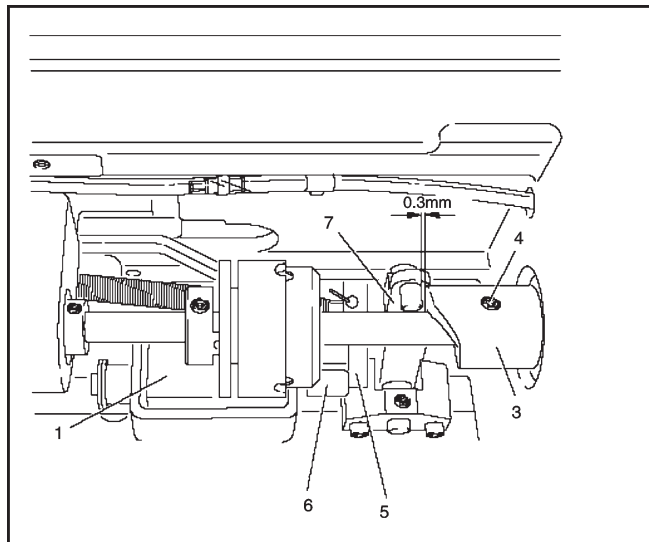

9.04.02 捕线器架的位置调整 Position of the thread catcher holder

规则

1. 在齿轮**3**和齿弧段零件**4**之间,应有一最小的间隙使其运动自如。
2. 在捕线器的空挡位置和最初位置,在齿弧段零件**4**和捕线器架**1**的外边缘之间的距离都应该是相同的(参见箭头)。

Requirement

1. there should be a minimum amount of play between toothed wheel **3** and toothed segment **4**.
2. both in the neutral position and the foremost position of the catcher, the distance between the toothed segment **4** and the outer edge of the thread catcher holder **1** should be the same (see arrow).



- 按照规则调整捕线器架**1**(螺钉**2**)。
- Adjust the thread catcher holder **1** (screws **2**) according to Requirements.



如果调整不能达到第2条规则的要求,拧松螺钉**2**并将齿弧段零件**4**移动一个齿啮合。

If **Requirement 2** cannot be fulfilled, loosen screw **2** and move the toothed segment **4** by one tooth.

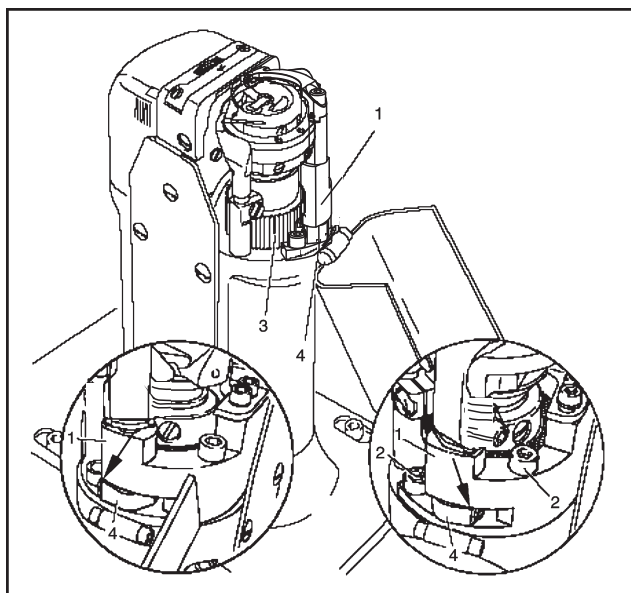

调整 Adjustment

9.04.03 捕线器与针板间的距离 Distance between thread catcher and needle plate

规则
在其摆动运动过程中，捕线器1不应越过针板的边缘（参见箭头）。

Requirement
During its swivel movement thread catcher 1 should not pass the edge of the needle plate (see arrow).



- 按照规则移动捕线器1（螺钉2，两个螺钉），使与捕线器架平行。
- Move thread catcher 1 (screws 2, two screws) parallel to the thread catcher holder in accordance with the **Requirement**.

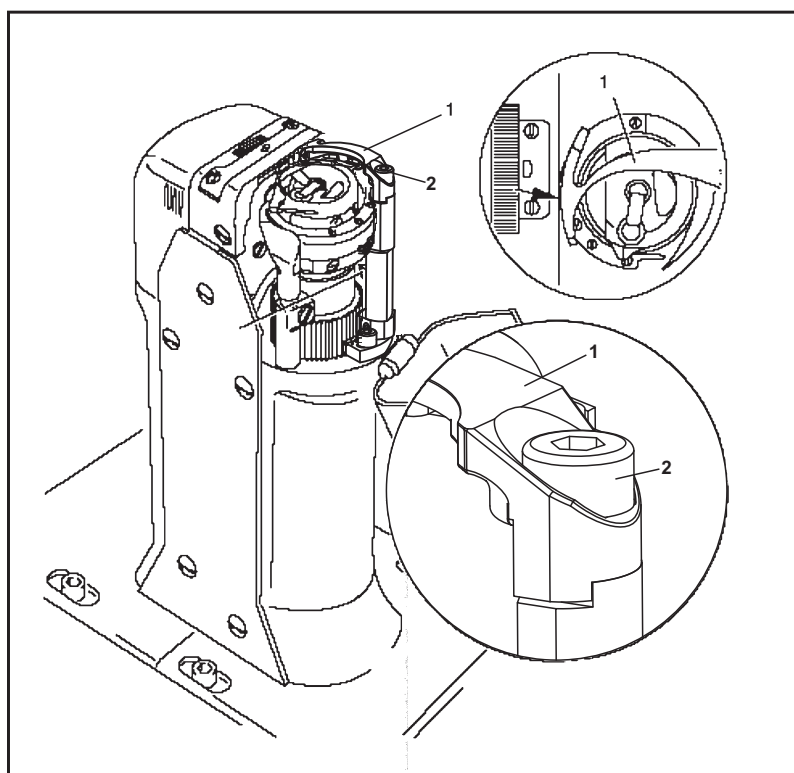

9.04.04 捕线器位置调整 Position of the thread catcher

规则

1. 在捕线器1的底边与梭壳定位指5之间应有**0.1 mm**的距离。
2. 当剪线器处于空挡位置时，捕线器的后边缘应定位在刀刃后面大约**2.5~3 mm**。

Requirement

1. the bottom edge of the thread catcher 1 should be at a distance of **0.1 mm** from the positioning finger of the bobbin case 5.
2. when the thread trimmer is in its neutral position, the rear edge of thread catcher should be positioned approx. **2.5 3 mm** behind the edge of the knife.



- 按照第1条规则移动捕线器1（螺钉2，两个螺钉）。
- 按照第2条规则转动捕线器1（螺钉3）。
- Move thread catcher 1 (screw 2, two screws) in accordance with Requirement 1.
- Turn thread catcher 1 (screw 3) in accordance with Requirement 2.



捕线器1必须与捕线器架4的表面平行。
Thread catcher 1 must be parallel to the surface of the thread catcher holder 4.

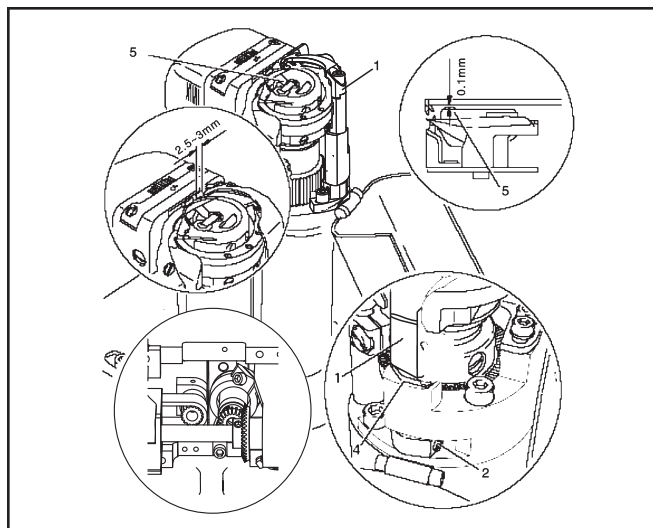

调整 Adjustment

9.04.05 切刀位置和切刀压力 Knife position and knife pressure

规则

1. 切刀1应与针板接触。
2. 应设置尽可能低的切刀压力，但剪线功能要可靠地完成。

Requirement

1. the knife 1 should be touching the needle plate.
2. the knife pressure should be set as low as possible but the cutting operation should still be carried out reliably.



- 按照第1条规则移动切刀1（螺钉2），或者按照第2条规则摆动切刀1来调整。
- Move knife 1 (screw 2) in accordance with **Requirement 1** or swivel it in accordance with **Requirement 2**.

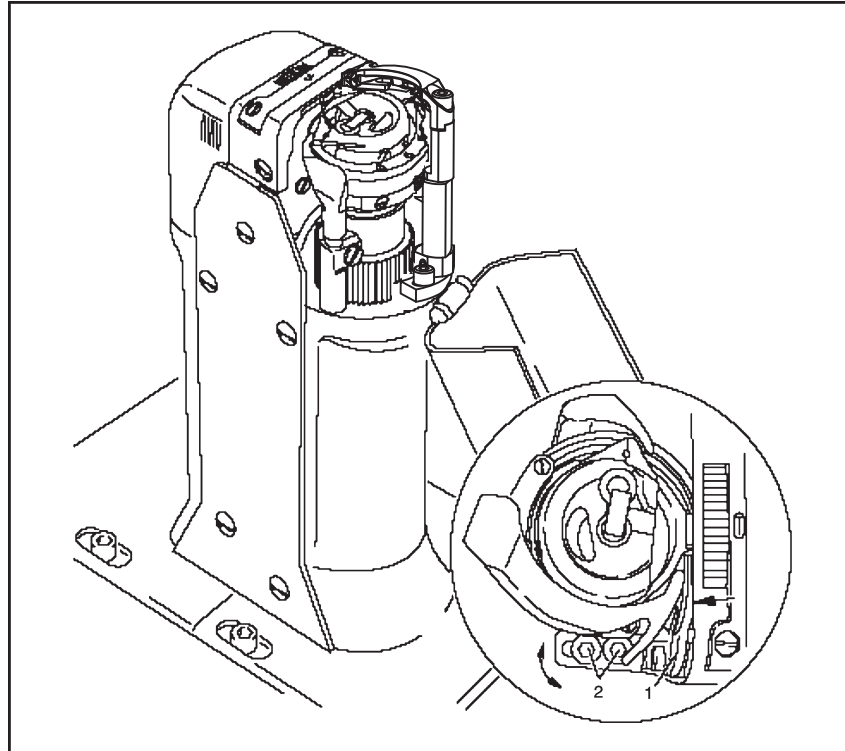

9.04.06 梭心线夹持弹簧 Bobbin thread retaining spring

规则

1. 梭心线夹持簧应在捕线器3的线槽中可靠地导向。
2. 梭心线夹持簧的压力应尽可能低，但在剪线动作后梭心线应可靠地被夹持住

Requirement

1. the bobbin thread clamp spring should be guided reliably in the thread groove of the thread catcher 3.
2. the tension of the bobbin thread spring clamp should be as low as possible, but the bobbin thread should be reliably after the cutting operation.

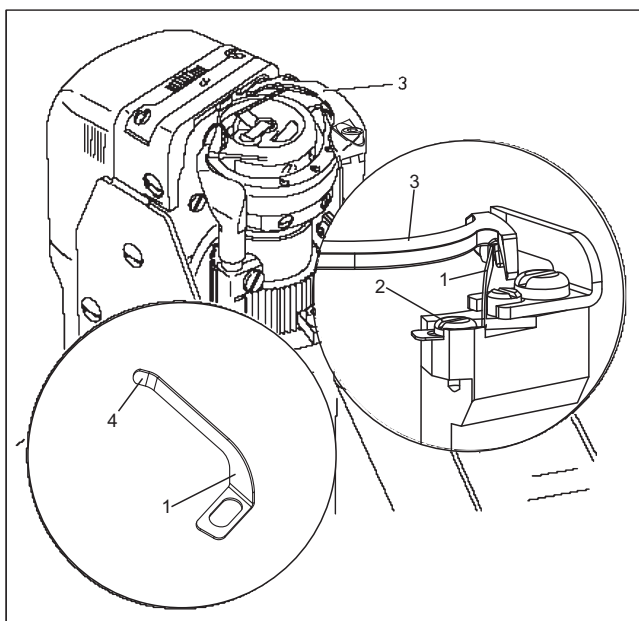

- 按照第1条规则调整梭心线夹持簧1（螺钉2）。
- 按照第2条规则，通过扳梭心线夹持簧1的侧边4来调整其压力。
- Adjust bobbin thread clamp spring 1 (screw 2) in accordance with **Requirement 1**.
- Adjust the tension in accordance with **Requirement 2** by bending side 4 of the bobbin thread clamp spring 1.

按第1条规则调节

- 关闭机器并使挑线杆位于下死点。
- 手动使捕线器3进入和脱离工作位置，并按第1条规则检查。如有必要做重新调整。

Control requirement 1

- Switch off the machine and bring the take-up lever to its bottom dead centre.
- Engage and disengage the thread catcher 3 by hand and check

Requirement 1. Adjust if necessary.

按第2条规则调节

- 在剪线后，通过转动手轮缝纫几个线迹，检查在第1个和第3个线迹之间是否梭心线被从夹持簧拉出，如有必要改进持紧簧压力。

Control requirement 2

- After the thread has been cut, sew a few stitches by turning the balance wheel, checking whether the bobbin thread is drawn out of the bobbin thread clamp spring between the 1st and 3rd stitched, if necessary, correct the tension.

调整 Adjustment

9.04.07 手动剪线试验 Manual cutting test

规则

1. 当捕线器1在其向前的行程时，它不能带着梭心线3也向前。
2. 当捕线器1在其前端位置时，钩件4必须可靠地保持住梭心线3。
3. 在剪线动作后，针线和梭心线都必须被完全剪断，并将梭心线3夹持住。

Requirement

1. when thread catcher 1 is on its forward stroke, it must not carry bobbin thread 3 forward too.
2. when thread catcher 1 is in its front position, bobbin thread 3 must be held reliably by hook 4.
3. After the trimming action, both the needle thread and the bobbin thread must be perfectly cut and bobbin thread 3 retained.

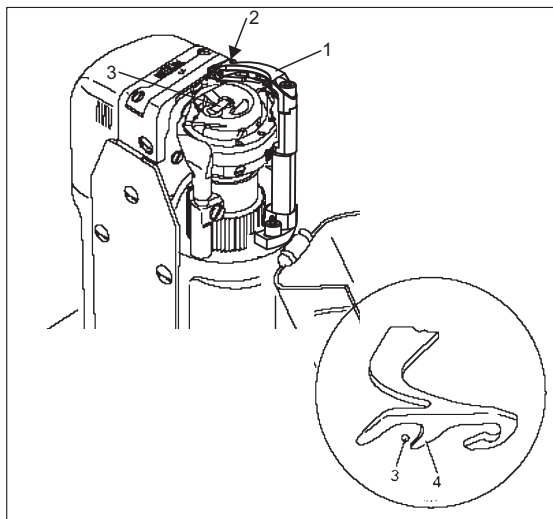

- 缝纫几个线迹。
- 关闭总电源开关。
- 手动完成剪线操作。
- 按第1和第2条规则检查，如果有必要可按照9.04.5节捕线器位置调整重新调整捕线器1。
- 按第3条规则检查，如果有必要可按照第9.04.06节梭心线夹持弹簧重新调整梭心线夹持弹簧2。

- Sew a few stitches.
- Turn off the on/off switch.
- Carry out the cutting operation manually.
- Check **Requirement 1** and **2**, and if necessary readjust thread catcher 1 in accordance with **Chapter 9.04.05 Position of the thread catcher**.
- Check **Requirement 3**, and if necessary readjust the bobbin thread retaining spring 2 in accordance with **Chapter 9.04.06 Bobbin thread retaining spring**.

9.04.08 联动杆调整(仅 9640机型有) Linkage rod (only for the 9640)

规则
当剪线器处于静止位置时，其驱动杠杆1之间必须是平行的。

Requirement
When the thread trimmer is in its resting position, the drive levers 1 must be parallel.

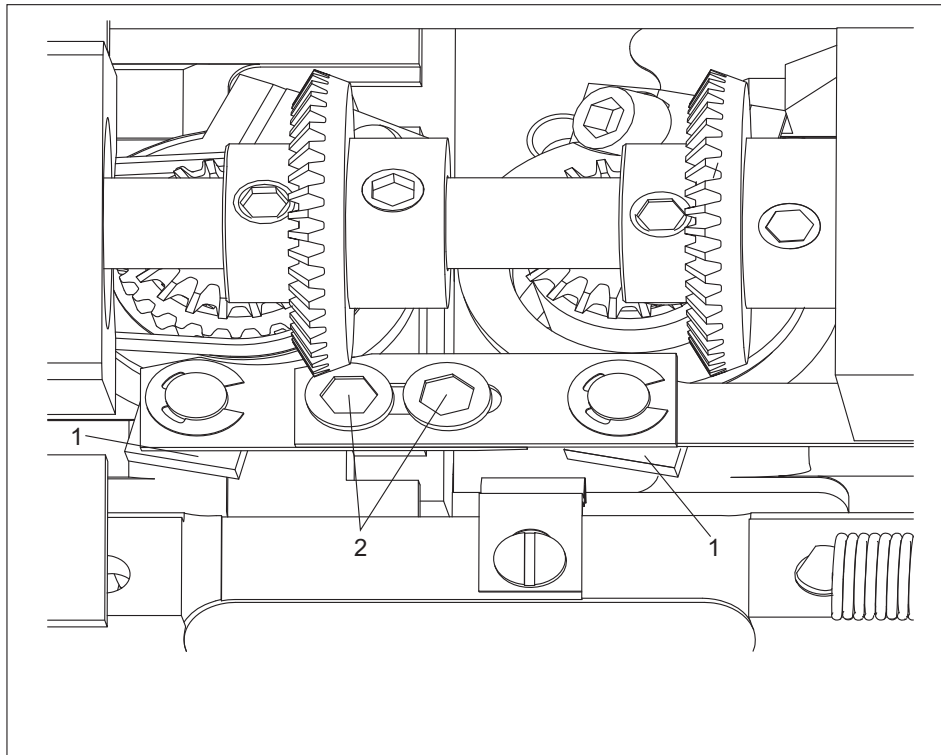

- 按照规则调整杠杆1（螺钉2）。
- Adjust drive levers 1 (screw 2) in accordance with the Requirement.

调整 Adjustment

9.04.09 机针在针孔中的位置（仅对于 9630 机型） Needle in needle hole (only for 9630)

规则

当设置最大线迹长度时，在顺缝和倒缝线迹情况下，机针在针孔中到针孔内边缘的距离必须是相同的。

Requirement

When the maximum stitch length is set, the needle must be the same distance from the inside edge of the needle hole, both for forward and reverse stitch.

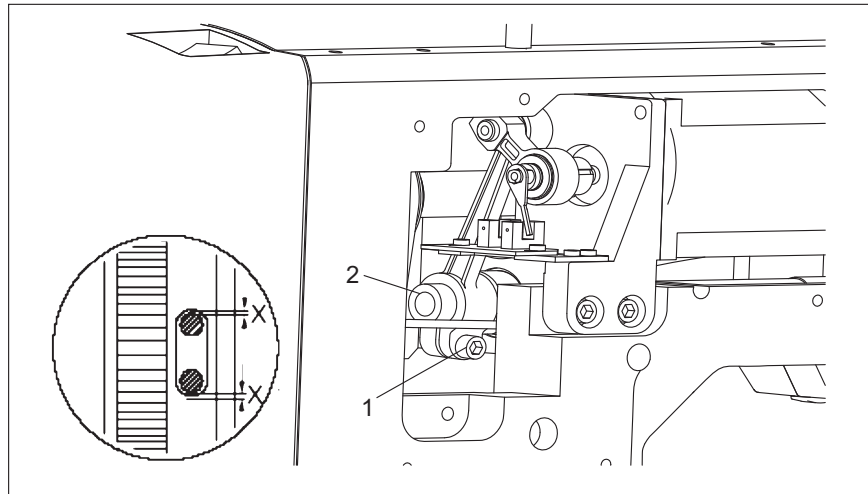

- 按照规则转动主轴2（螺钉1）来调整。
- Turn axis 2 (screw 1) according to the Requirement,

零件手册

PARTS BOOK

1. 机身部件

Housing sections

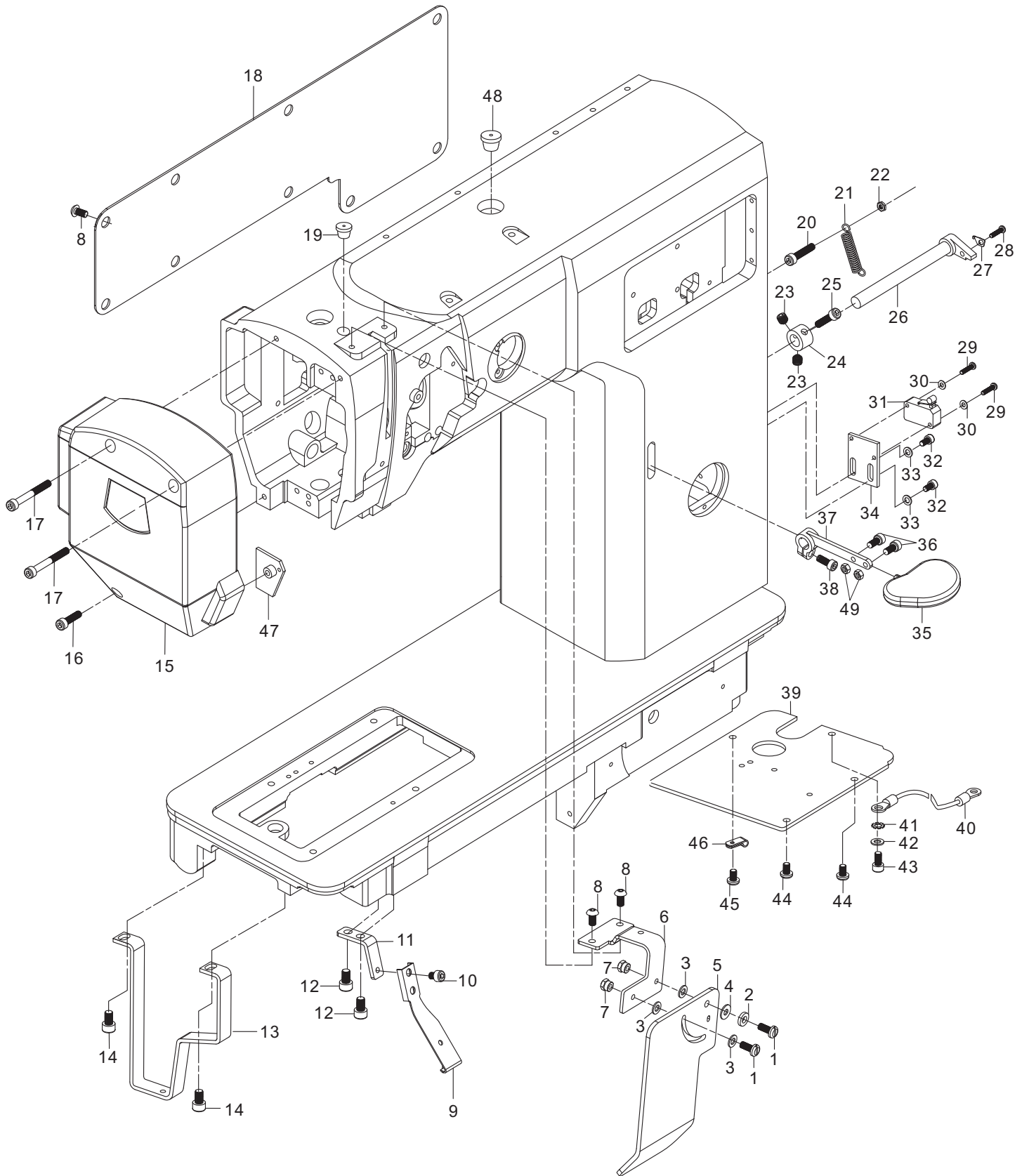

1. 机身部件

Housing sections

序号 No.	件号 Part No.	名称	DESCRIPTION	数量 Qty
1	10005271	螺钉 M5×12	Screw M5×12	2
2	10003235	垫圈 Φ5	Washer Φ5	1
3	10005016	垫圈 Φ5	Washer Φ5	4
4	10001413	垫圈 Φ5	Washer Φ5	1
5	10001607	防护板	Protection apron	1
6	20003964	防护板支架	Protection apron bracket	1
7	10003021	螺母 M5	NUT M5	2
8	10007096	螺钉 M5×10	Screw M5×10	11
9	10005187	安全板	Safety plate	1
10	10005539	螺钉 M5×6	Screw M5×6	1
11	10005008	支板	Trestle board	1
12	10005122	螺钉 M6×10	Screw M6×10	2
13	10054582	支脚	Bracket	1
14	10004974	螺钉 M6×10	Screw M6×10	2
15	10057383	步进机面板	Panel	1
16	10003141	螺钉 M5×20	Screw M5×20	1
17	10041446	螺钉 M5×45	Screw M5×45	2
18	20021234	侧盖板	Lateral board	1
19	10005124	油塞	Oil dam	1
20	10007637	螺钉 M5×40	Screw M5×40	1
21	10041260	倒缝杆弹簧	Spring	1
22	10002952	螺母 M5	NUT M5	1
23	10011802	SM11/64"×40螺钉	Screw SM11/64"×40	2
24	10000378	倒送料轴挡圈	Thrust collar for feeding axis	1
25	10000560	SM11/64"×40螺钉	Screw SM11/64"×40	1
26	10057382	倒缝扳手轴	Axis of spanner for reversal stitch	1
27	10005287	弹簧固定板	Spring fix board	1
28	10005186	螺钉 M4×8	Screw M4×8	1
29	10001368	螺钉 M3×14	Screw M3×14	2
30	10002068	垫圈 Φ3	Washer Φ3	2
31	10035679	倒缝点动开关	Power switch	1
32	10005350	螺钉 M4×8	Screw M4×8	2
33	10005260	垫圈 Φ4	Washer Φ4	2
34	10057392	开关安装板	Mounting plate	1
35	10057379	倒缝扳手	Spanner of reversal stitch	1
36	10012752	螺钉 M4×10	Screw M4×10	2
37	10057380	扳手挡圈	Thrust collar for spanner	1
38	10005139	螺钉 M5×12	Screw M5×12	1
39	10041476	底板盖板	Bottom cover	1
40	10005458	接地线组件	Ground lead	1
41	10005425	外齿锁紧垫圈 Φ5	Washer Φ5	1
42	10005016	垫圈 Φ5	Washer Φ5	1
43	10005322	螺钉 M5×10	Screw M5×10	1
44	10005003	螺钉 M5×8	Screw M5×8	2
45	10005513	螺钉 M4×8	Screw M4×8	1
46	10008228	SN-3A夹头	Clamp	1
47	10001414	面板油箱盖	Plate of panel lube tank	1
48	10005501	油塞	Oil dam	1
49	10003027	螺母M4	NUT M4	2

2. 机头零件(1) Needle head parts (1)

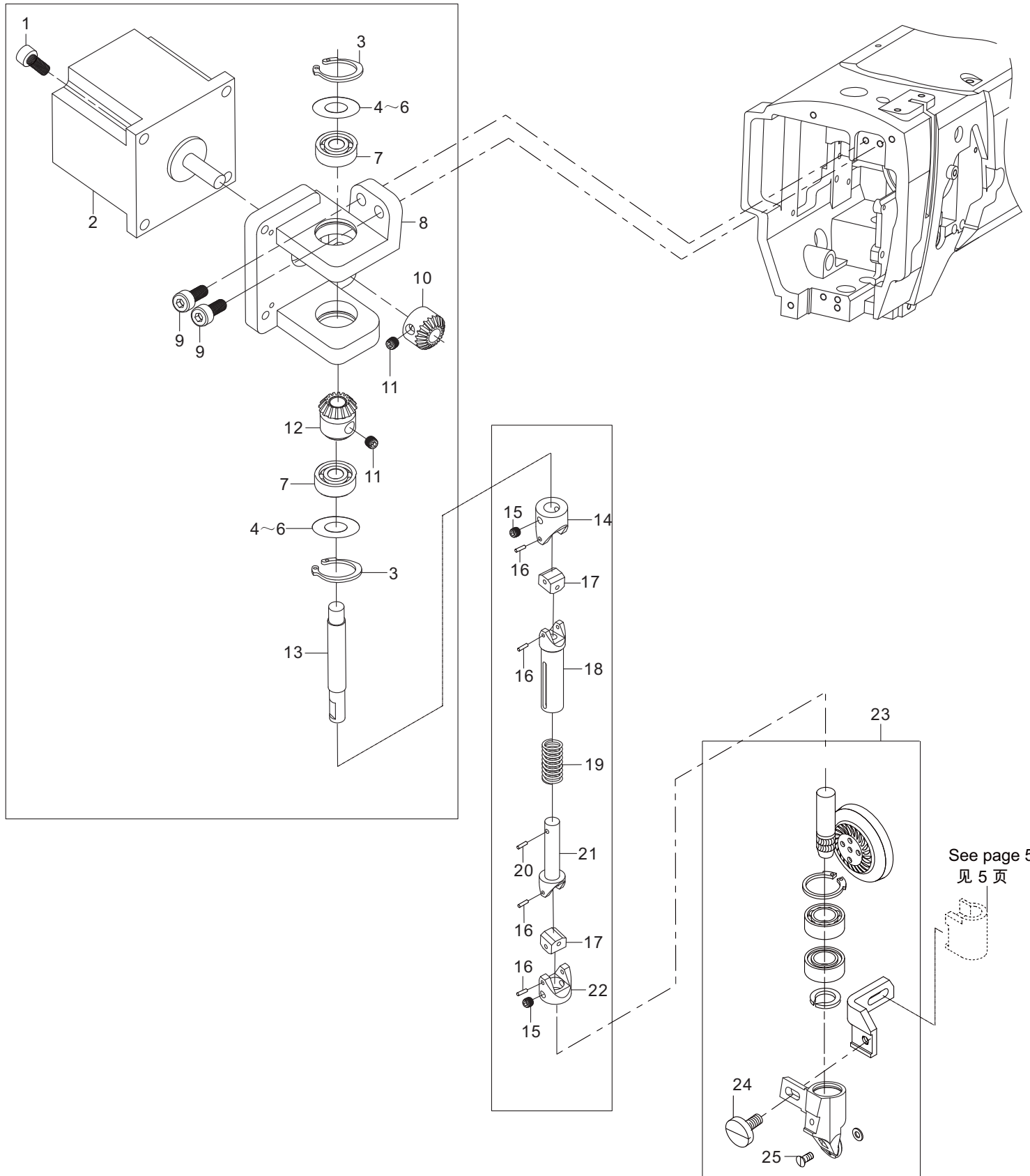

2. 机头零件 (1)

Needle head parts (1)

序号 No.	件号 Part No.	名称	DESCRIPTION	数量 Qty
1	10059082	M5×16螺钉	Screw M5×16	3
2	10062956	送料步进电机	Feeding stepping motor	1
3	10052006	挡圈	Retaining ring	2
4	10057361	调节垫片 0.15	Adjusting washer 0.15	2
5	10057362	调节垫片 0.3	Adjusting washer 0.3	2
6	10057363	调节垫片 0.5	Adjusting washer 0.5	2
7	10027118	轴承	Bearing	2
8	10057360	上送料支座	Above feeding support	1
9	10003164	螺钉 M5×16	Screw M5×16	2
10	10008672	574倒缝传动齿轮 II	574 Backstitch transmission gear	1
11	10005549	M6×5螺钉	Screw M6×5	4
12	10007075	574倒缝传动齿轮 I	574 Backstitch transmission gear	1
13	10062393	转轴A	Axis A	1
14	10056359	万向头A	Universal joint A	1
15	10009741	M4×6螺钉	Screw M4×6	2
16	10039834	滚针P2×11.8	Needle roller P2×11.8	4
17	10056362	联接块	Connecting block	2
18	10056357	万向连杆	Universal connecting rod	1
19	10053250	压缩弹簧	Pressure spring	1
20	10053251	滚针P2.5×13.8	Needle roller P2.5×13.8	1
21	10056358	万向轴	Idler wheel foot asm	1
22	10056360	万向头B	Universal joint B	1
23	10056370	滚轮压脚组件	Idler wheel foot asm	1
24	10005243	螺钉 M4×8	Screw M4×8	1
25	10005070	螺钉 M2.5×6	Screw M2.5×6	1

3. 机头零件(2) Needle head parts (2)

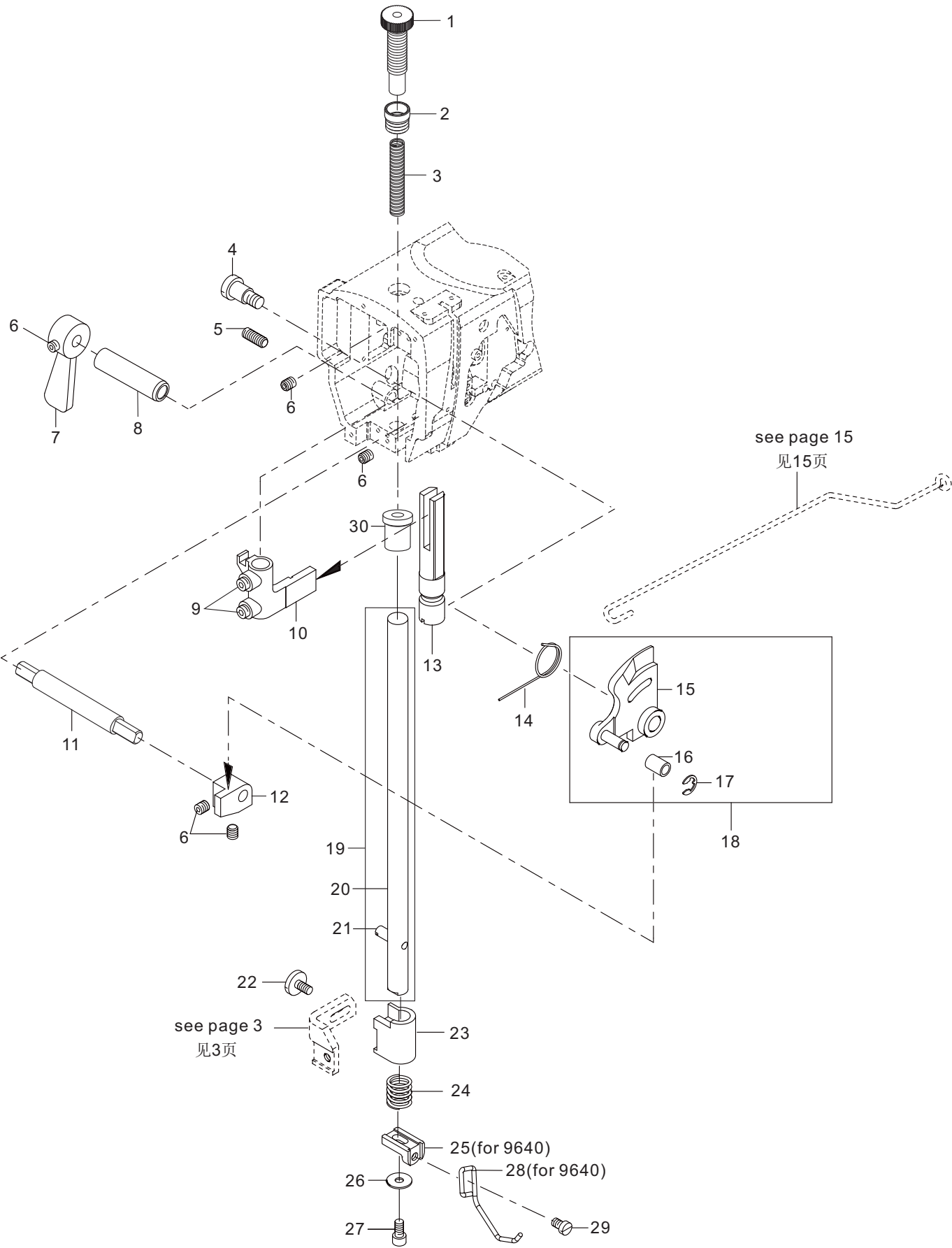

3. 机头零件 (2)

Needle head parts (2)

序号 No.	件号 Part No.	名称	DESCRIPTION	数量 Qty
1	10057364	调压螺钉	Adjusting pressure screw	1
2	10057365	调压锁紧螺母	Adjusting pressure jam nut	1
3	10057366	压紧弹簧	Compress spring	1
4	10005312	螺钉 M6×8	Screw M6×8	1
5	10009187	螺钉 M6×8	Screw M6×8	1
6	10012162	螺钉 M5×5	Screw M5×5	5
7	20003486	压脚扳手	Presserfoot spanner	1
8	10005412	抬压脚手柄轴套	Presser feet handle bushing	1
9	10005549	螺钉 M6×5	Screw M6×8	2
10	10005208	压杆滑块	Strut bar slides	1
11	10005011	抬压脚轴	Presser foot lift axle	1
12	10005543	抬压脚凸块	Presser foot lift bump	1
13	10005192	压杆滑块导杆	Strut bar slides guide bar	1
14	10005418	松线复位簧	Replacement spring	1
15	10005239	抬压脚前杠杆焊接件	Presser foot lift jointing	1
16	10005406	抬压脚前杠杆销套	Presser foot lift pin	1
17	10005078	挡圈	Collar	1
18	10039313	抬压脚前杠杆组件	Presser foot lift asm	1
19	10005178	压脚杆组件	Presser feet assembly	1
20	10005247	压脚杆	Presser feet	1
21	10005422	下节销螺钉 M4×5.2	Screw M4×5.2	1
22	10005243	螺钉 M4×8	Screw M4×8	1
23	10005068	压脚柄	Presser feet handle	1
24	10005460	压簧	Pressure spring	1
25	10001492	压料器定位座 (for 9640)	Eccentric swage locating seat (for 9640)	1
26	10005415	垫圈 Φ4	Washer Φ4	1
27	10005350	螺钉 M4×8	Screw M4×8	1
28	10030364	压料簧 (for 9640)	Eccentric swage spring (for 9640)	1
29	10005204	螺钉 M4×6	Screw M4×6	1
30	10057367	压杆下套	Presser busing	1

4. 机头零件(3) Needle head parts (3)

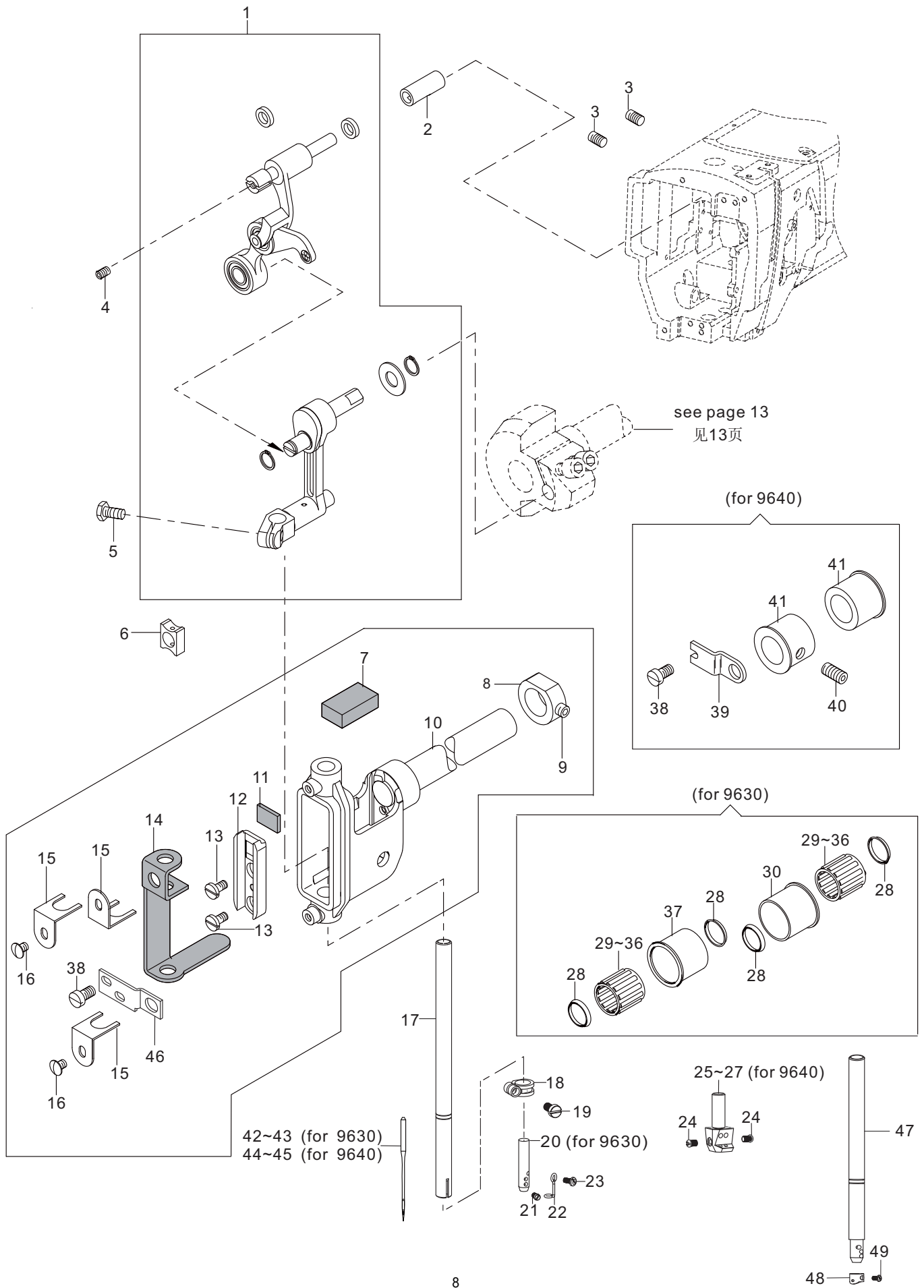

4. 机头零件 (3)

Needle head parts (3)

序号 No.	件号 Part No.	名称	DESCRIPTION	数量 Qty
1	10005207	挑线杆组件	Takeuplever assembly	1
2	10005267	挑线连杆销衬套	Takeuplever pin bushing	1
3	10004949	螺钉 M5×8	Screw M5×8	2
4	10005295	螺钉 M4×5	Screw M4×5	1
5	10005314	螺栓 M5×10	Screw M5×10	1
6	10005326	针杆连接柱滑块	Needle joining slider	1
7	10005275	油毡	Felt	1
8	10040233	针杆架轴挡圈	Uper check ring	1
9	10005258	螺钉 M6×0.75×5	Screw M6×0.75×5	1
10	10005397	针杆架件	Needle bar assembly	1
11	10005188	油毡	Felt	1
12	10005263	针杆滑块槽	Needle slider groove	1
13	10005379	螺钉 M4×4.5	Screw M4×4.5	2
14	10004947	油毡	Felt	1
15	10005197	油毡压板	Linoleum clamp	3
16	10005050	螺钉 M4×4	Screw M4×4.5	1
17	10005491	针杆上节	Needle bar uper	1
18	10005181	针杆锁紧圈	Needle bar clamp ring	1
19	10005209	螺钉 M4×8	Screw M4×8	1
20	10005214	针杆下节 (For 9630)	Pin chuck (for 9630)	1
21	10005478	机针锁紧螺钉 M4×8	Screw M4×8	1
22	10004943	下过线钩	Arm thread guide	1
23	10005547	螺钉 M3×6	Screw M3×6	1
24	10001578	螺钉 M3×3.2	Screw M3×3.2	2
25	10001494	3.2针夹头 (For 9640)	Pin chuck 3.2 (For 9640)	(1)
26	10002199	2.8针夹头 (For 9640)	Pin chuck 2.8 (For 9640)	(1)
27	10001421	2.4针夹头 (For 9640)	Pin chuck 2.4 (For 9640)	(1)
28	10005031	内卡圈	Inner retainer ring	4
29	10005408	滚针轴承	Needle bearing	(2)
30	10007188	滚针轴承	Needle bearing	(2)
31	10007189	滚针轴承	Needle bearing	(2)
32	10007190	滚针轴承	Needle bearing	(2)
33	10007191	滚针轴承	Needle bearing	(2)
34	10007192	滚针轴承	Needle bearing	(2)
35	10007193	滚针轴承	Needle bearing	2
36	10007194	滚针轴承	Needle bearing	(2)
37	10004952	上边轴轴承套	Bearing bush	2
38	10001493	螺钉 M5×6	Screw M5×6	2
39	10008050	定位板	Guide plate	1
40	10002163	螺钉 M6×14	Screw M6×14	1
41	10008049	针杆架轴套	Needle bar bush	2
42	10006103	机针134PCL90/14 (for 9630-M)	Neddle 134PCL 90/14 (for 9630-M)	1
43	10004103	机针134PC120/19 (for 9630-H)	Neddle 134PCL 120/19 (for 9630-H)	(1)
44	10001375	机针134-35 90/14 (for 9640-M)	Neddle 134-35 90/14 (for 9640-M)	2
45	10030202	机针134-35120/19 (for 9640-H)	Neddle 134-35 120/19 (for 9640-H)	(2)
46	10057385	摆针限位板	Neddle limit board	1
47	10059855	单针针杆B	Needle bar B	1
48	10013181	针杆线钩	Thread hook	1
49	10005478	M3×4螺钉	Screw M3×4	1

5. 机头零件(4) Needle head parts (4)

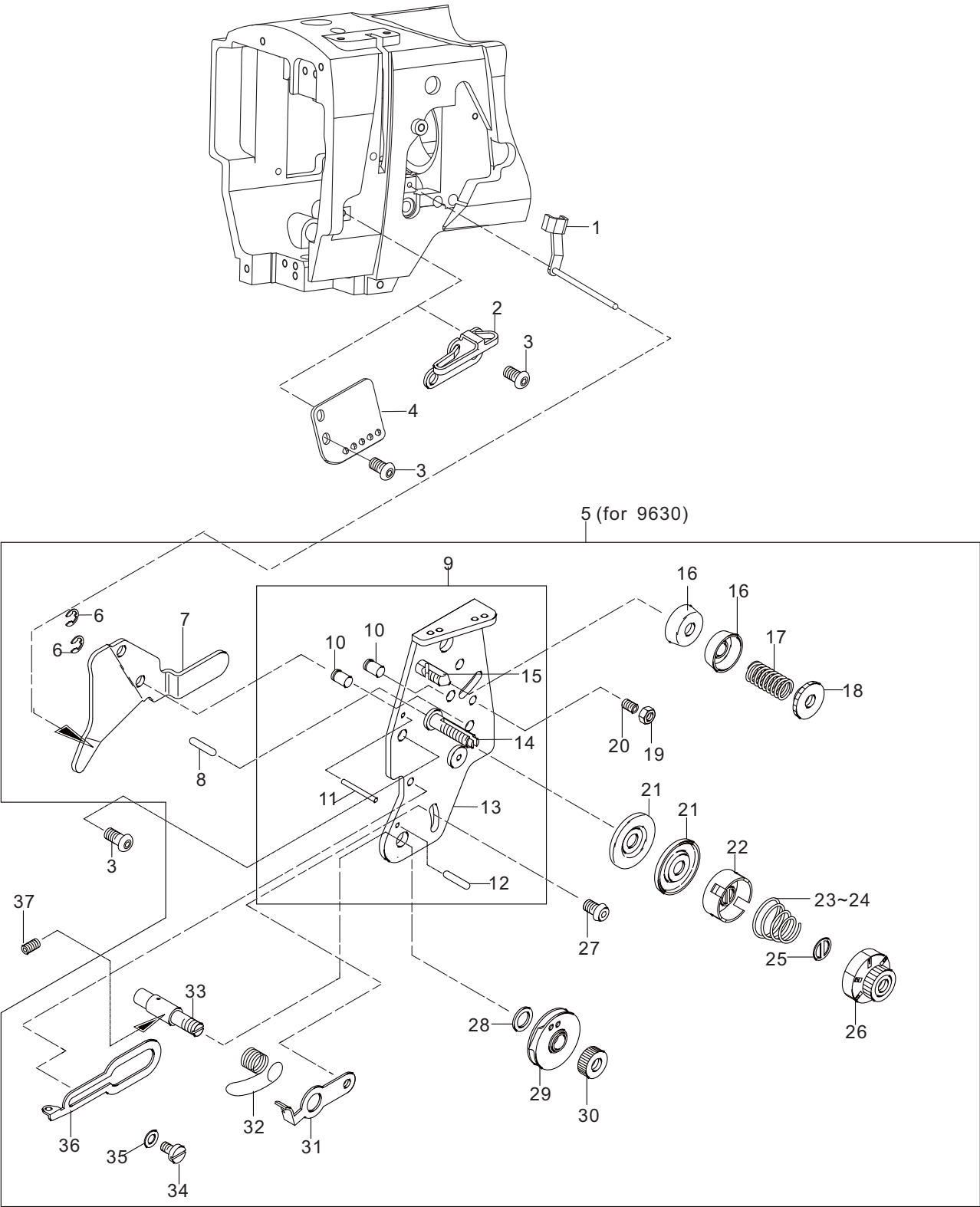

5. 机头零件 (4)

Needle head parts (4)

序号 No.	件号 Part No.	名称	DESCRIPTION	数量 Qty
1	10001657	电磁铁挺线钉	Tension release crank	1
2	10005118	左右过线勾	Left and right wire hook	1
3	10007096	螺钉 M5×10	Screw M5×10	4
4	10052849	大过线勾	Thread guide plate	1
5	10004080	夹线器 (9630专用)	Conductor holder for 9630	1
6	10009669	卡圈	Collar	2
7	10004977	挑线簧限位板	Spring guard	1
8	10005252	过线钉	Pin	1
9	10005302	夹线大板组件	Bobbin winder tension disc asm	1
10	10005032	销钉 5×8	Screw pin 5×8	2
11	10005289	防转长销钉 2×20	Screw pin 5×8	1
12	10005316	防转销钉 2×8	Screw pin 5×8	1
13	10004941	夹线大板	Bobbin winder tension disc	1
14	10005554	螺钉	Screw	1
15	10005548	夹线调压螺钉	Screw	1
16	10005019	调节簧座	Thred tension disk	2
17	10005241	夹线调节弹簧	Spring	1
18	10005190	夹线调节螺母 M6	Screw M6	1
19	10005328	挺线电磁铁调节螺母 M4	Screw M4	1
20	10003147	螺钉 M4×8	Screw M4×8	1
21	10005489	过线板	Thread guide plate	2
22	10005210	夹线簧座	Split line spring plate	1
23	10005014	夹线簧-薄料 (—M机型)	Split line spring (for —M Model)	1
24	10005347	夹线簧-厚料 (—H机型)	Split line spring (for —H Model)	(1)
25	10005317	压簧板	Spring plate	1
26	10005304	夹线螺母	NUT	1
27	10005107	螺钉 M4×6	Screw M4×6	1
28	10005056	垫片 Φ7.3	Washer Φ5	1
29	10005329	挑线过线焊件	Balance thread guide	1
30	10005538	挑线簧组件螺母 M6×0.75	NUT M6×0.75	1
31	10005417	挡簧块	E-ring	1
32	10005067	挑线簧	Spring	1
33	10005505	夹线过线轴	Thread guide spindle	1
34	10005299	螺钉 M4×5	Screw M4×6	1
35	10003122	垫圈 Φ4	Washer Φ4	1
36	10005429	过线调节板	Thread guide plate	1
37	10004949	螺钉 M5×8	Screw M4×6	1

6. 机头零件(5) Needle head parts (5)

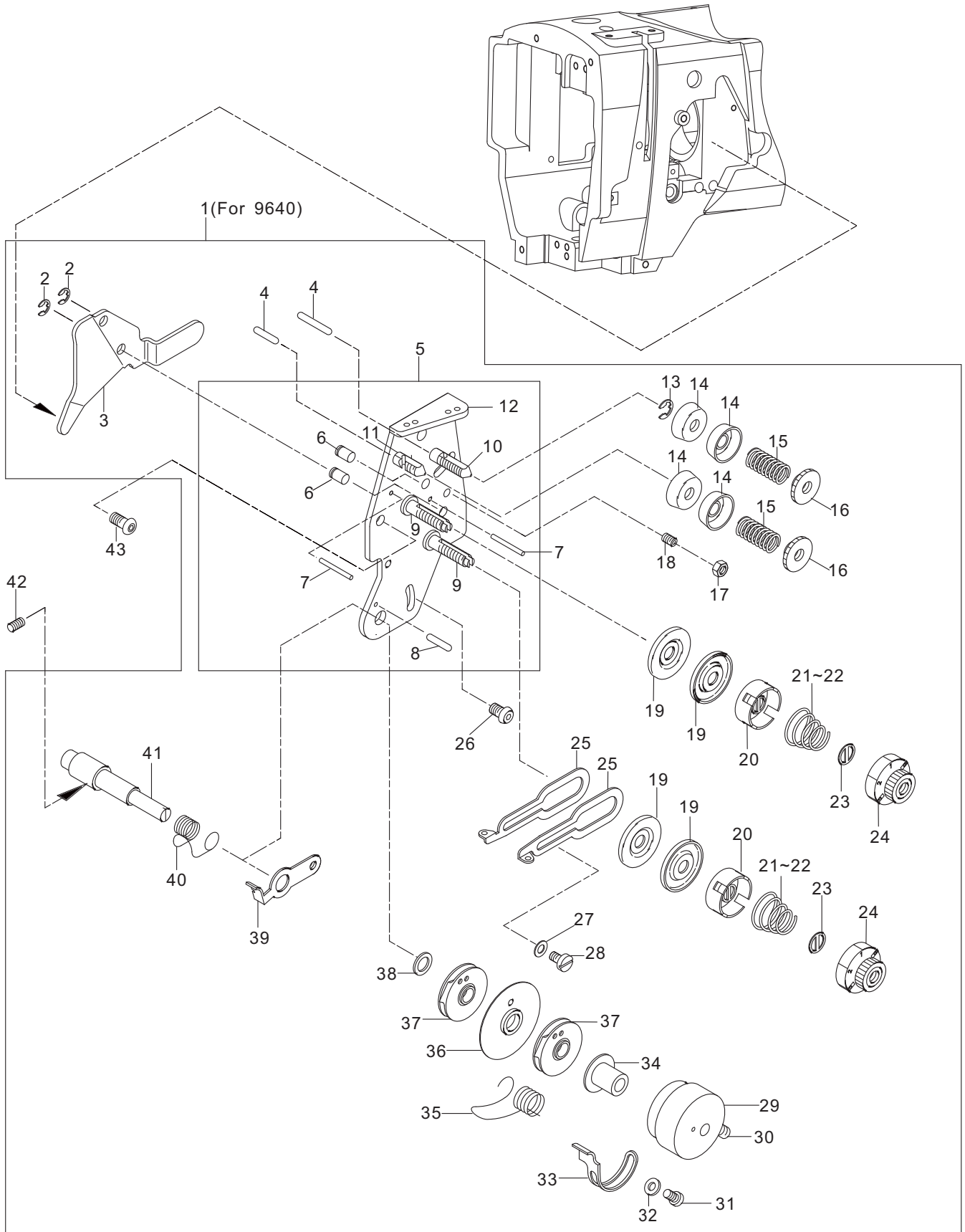

6. 机头零件 (5)

Needle head parts (5)

序号 No.	件号 Part No.	名称	DESCRIPTION	数量 Qty
1	10014515	夹线器 (9620专用)	Conductor holder (for 9620)	1
2	10009669	卡圈	Collar	2
3	10004977	挑线簧限位板	Spring guard	1
4	10005252	过线钉	Pin	1
5	10005302	夹线大板组件	Bobbin winder tension disc asm	1
6	10005032	销钉 5×8	Screw pin 5×8	2
7	10005289	防转长销钉 2×20	Screw pin 2×20	2
8	10005316	防转销钉 2×8	Screw pin 2×8	1
9	10005554	螺钉	Screw	2
10	10001534	夹线调压螺钉 I	Screw	1
11	10005548	夹线调压螺钉	Screw	1
12	10004941	夹线大板	Bobbin winder tension disc	1
13	10005078	卡圈	Collar	1
14	10005019	调节簧座	Thred tension disk	4
15	10005241	夹线调节弹簧	Spring	2
16	10005190	夹线调节螺母 M6	Nut M6	2
17	10005328	挺线电磁铁调节螺母 M4	Nut M4	1
18	10003147	螺钉 M4×8	Screw M4×8	1
19	10005489	过线板	Thread guide plate	4
20	10005210	夹线簧座	Split line spring plate	2
21	10005014	夹线簧-薄料 (—M机型)	Split line spring (for —M Model)	2
22	10005347	夹线簧-厚料 (—H机型)	Split line spring (for —H Model)	(2)
23	10005317	压簧板	Spring plate	2
24	10005304	夹线螺母	Nut	2
25	10005429	过线调节板	Thread guide plate	2
26	10005107	螺钉 M4×6	Screw M4×6	1
27	10003122	垫圈 Φ4	Washer Φ4	1
28	10005299	螺钉 M4×5	Screw M4×6	1
29	10001495	挑线簧调节转动套筒	Sleeve	1
30	10002856	螺钉 M4×4	Screw M4×6	1
31	10003034	螺钉 M3×5	Screw M3×5	1
32	10003071	垫圈 Φ3	Washer Φ3	1
33	10002009	挡簧块 I	E-ring I	1
34	10001496	套环	Pipe casing	1
35	10002404	挑线簧 I	Spring I	1
36	10001532	挑线簧隔板	Partition board	1
37	10005329	挑线过线焊件	Balance thread guide	2
38	10005056	垫片 Φ7.3	Washer Φ5	1
39	10005417	挡簧块	E-ring	1
40	10005067	挑线簧	Spring	1
41	10001531	挑线簧调节轴	Adjustment axle	1
42	10004949	螺钉 M5×8	Screw M4×6	1
43	10007096	螺钉 M5×10	Screw M5×10	1

7. 机臂零件(1) Arm parts (1)

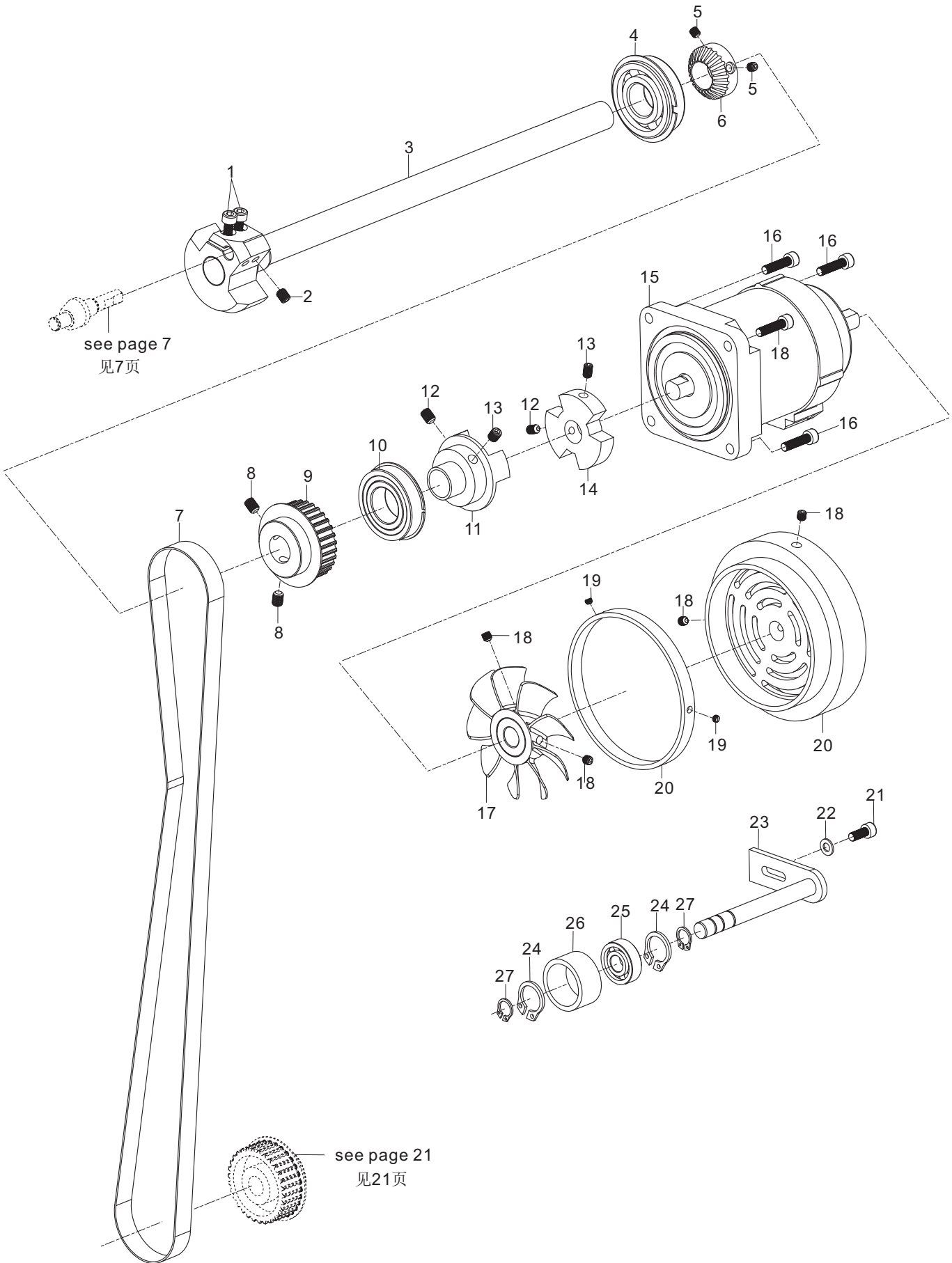

7. 机臂零件 (1)

Arm parts (1)

序号 No.	件号 Part No.	名称	DESCRIPTION	数量 Qty
1	10010953	螺钉 M5×10	Screw M5×10	2
2	10005466	螺钉 M6×0.75×7	Screw M6×0.75×7	1
3	10041482	曲柄主轴组件	Counter weight assy	1
4	10003578	主轴前轴承 6204ZZNR	Bearing 6204ZZNR	1
5	10012162	螺钉 M5×5	Screw M5×5	2
6	10054658	绕线主动轮	Pulley	1
7	10041479	一体机同步带	Synchronous belt	1
8	10009187	螺钉 M6×8	Screw M6×8	2
9	10041636	主轴宽带轮	Spindle Pulley	1
10	10041481	轴承NSK 60/22ZZNR	Bearing 60/22ZZNR NSK	1
11	10041480	主轴联轴器	Coupling	1
12	10005300	螺钉 M6×0.75×8	Screw M6×0.75×8	2
13	10004938	螺钉 M6×0.75×8	Screw M6×0.75×8	2
14	10042979	电机联轴器组件	Coupling rubber	1
15	10062954	主轴电机	Axis Motor	1
16	10000157	螺钉 M5×18.5	Screw M5×18.5	4
17	10041729	一体机风扇	Fan	1
18	10004949	螺钉 M5×8	Screw M5×5	4
19	10006279	螺钉 M4×2.8	Screw M4×2.8	2
20	20018197	一体机手轮喷漆	Uppper wheel	1
21	10005139	螺钉 M5×12	Screw M5×12	1
22	10005016	垫圈 Φ5	Washer Φ5	1
23	10057391	同步带压紧焊接件	Seal part	1
24	10027928	挡圈	Collar	2
25	10003576	轴承 6000ZZ	Bearing 6000ZZ	1
26	10005396	皮带压紧器轴承套	Bearing bush	1
27	10004945	挡圈	Collar	2

8. 机臂零件(2)

Arm parts (2)

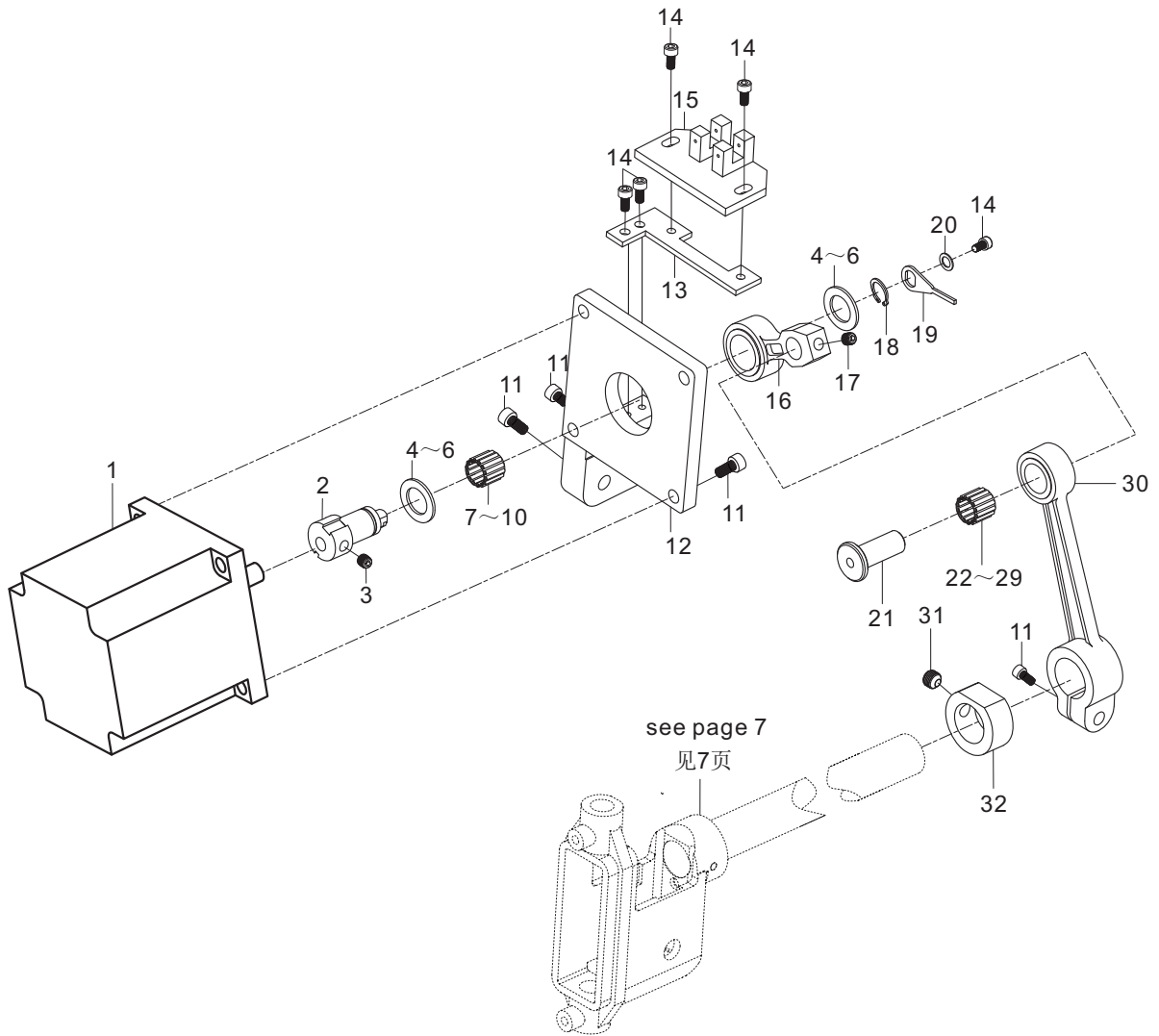

8. 机臂零件 (2)

Arm parts (1)

序号 No.	件号 Part No.	名称	DESCRIPTION	数量 Qty
1	10062955	摆针步进电机	Stepping motor	1
2	10057369	偏心轴	Ecentric axis	1
3	10009741	M4×6螺钉	Screw M4×6	1
4	10057374	Φ10垫片	Washer Φ10	2
5	10063319	Φ10垫片	Washer Φ10	(2)
6	10063320	Φ10垫片	Washer Φ10	(2)
7	10057525	K10×13×10滚针轴承	Needle bearing K10×13×10	1
8	10057526	K10×13×10滚针轴承	Needle bearing K10×13×10	(1)
9	10057371	K10×13×10滚针轴承	Needle bearing K10×13×10	(1)
10	10057372	K10×13×10滚针轴承	Needle bearing K10×13×10	(1)
11	10005139	M5×12螺钉	Screw M5×12	4
12	10057368	针送电机座	Motor support	1
13	10057375	传感器安装板	Plate for install sensor	1
14	10002975	M3×6螺钉	Screw M3×6	5
15	10063777	传感器	Sensor	1
16	10057370	曲柄连杆	Reciprocation rod	1
17	10004949	M5×8螺钉	Screw M5×8	1
18	10003277	挡圈	Thrust collar	1
19	10057376	传感片	Sensor pieces	1
20	10062255	传感片垫圈	Washer	1
21	10005047	针距调节连杆销	Pin	1
22	10005035	K8×11×10滚针轴承	Needle bearing K8×11×10	(1)
23	10007195	K8×11×10滚针轴承	Needle bearing K8×11×10	(1)
24	10007196	K8×11×10滚针轴承	Needle bearing K8×11×10	(1)
25	10007197	K8×11×10滚针轴承	Needle bearing K8×11×10	(1)
26	10007198	K8×11×10滚针轴承	Needle bearing K8×11×10	(1)
27	10007199	K8×11×10滚针轴承	Needle bearing K8×11×10	(1)
28	10007367	K8×11×10滚针轴承	Needle bearing K8×11×10	(1)
29	10007368	K8×11×10滚针轴承	Needle bearing K8×11×10	(1)
30	10057373	针送连杆	Needle feeding connecting rod	1
31	10005258	M6×0.75×5螺钉	Screw M6×0.75×5	1
32	10040233	针杆架轴挡圈	Thrust collar	1

9. 机臂零件(3) Arm parts (3)

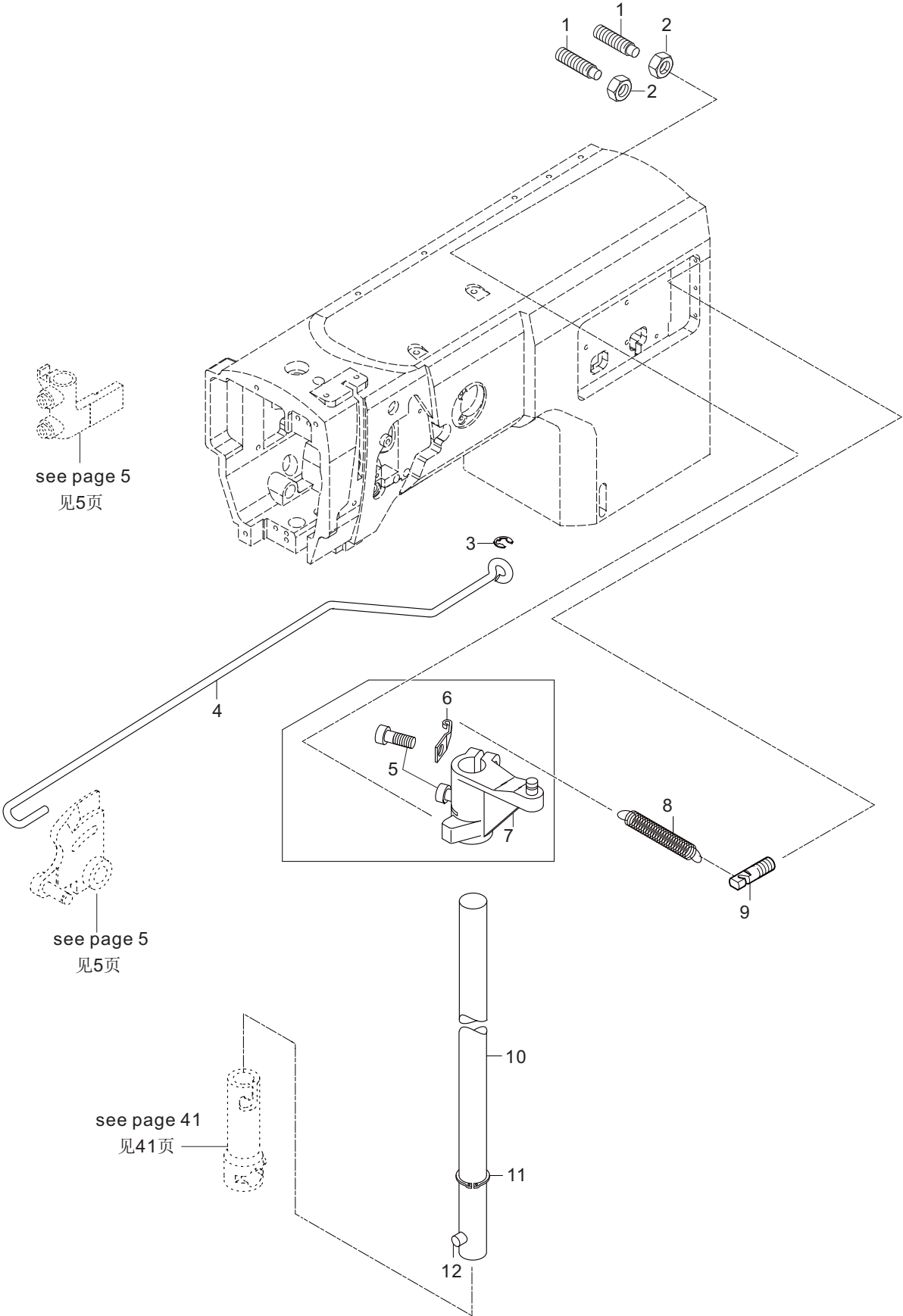

9. 机臂零件 (3)

Arm parts (3)

序号 No.	件号 Part No.	名称	DESCRIPTION	数量 Qty
1	10005001	螺钉 M6×30	Screw M6×30	2
2	10059873	调节螺母 M6	Nut M6	2
3	10005078	卡圈	collar	1
4	10055048	压脚拉杆B	Connecting rod	1
5	10005139	螺钉 M5×12	Screw M5×12	2
6	10005287	弹簧固定板	Spring Board	1
7	10005233	脚杆动轴曲柄组件	Crank	1
8	10041445	脚杆动轴拉簧	Spring	1
9	10005318	螺钉 M6×8	Screw M6×8	1
10	10006434	脚杆动轴组件	Moving axis assm	1
11	10005345	卡圈	Collar	1
12	10004983	销 5×14	Pin 5×14	1

10. 机臂零件(4)

Arm parts (4)

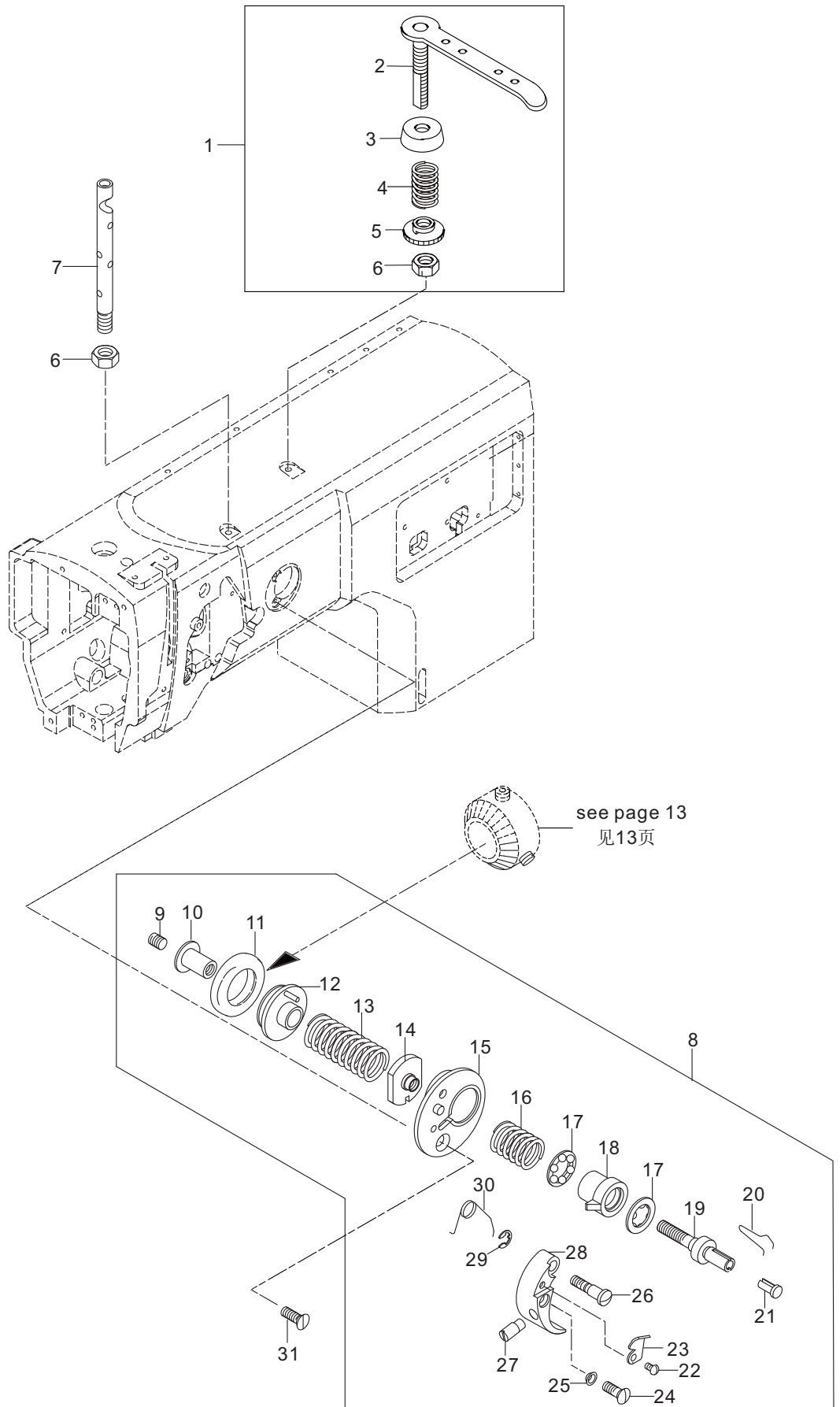

10. 机臂零件 (4)

Arm parts (4)

序号 No.	件号 Part No.	名称	DESCRIPTION	数量 Qty
1	10005108	过线器	Thread guide	1
2	10004976	过线杆组件	Thread crossing column assy	1
3	10005359	调节簧座	Thred tension disk	1
4	10005069	过线器压簧	Spring	1
5	10005520	夹线调节螺母 M6	Nut M6	1
6	10004970	六角螺母 M6	Nut M6	2
7	10005384	过线柱	Thread crossing column	1
8	10005149	绕线器	Bobbin winder unit	1
9	10012162	螺钉 M5×5	Screw M5×5	1
10	10004954	螺杆座	Screw plate	1
11	10005545	橡胶轮	Ring	1
12	10005261	绕线轮座组件	Bobbin winder shaft compl.	1
13	10005404	下压簧	Compression spring	1
14	10005075	压簧座	Compression spring seat	1
15	10005120	线圈板组件	Retaining ring assy	1
16	10005516	上压簧	Compressing spring	1
17	10005324	端面轴承	Edge bearing	2
18	10005235	芯轴衬套	Shaft bush	1
19	10005110	芯轴	Shaft	1
20	10005319	梭芯簧	Shuttle spring	1
21	10004986	梭芯衬套	Shuttle bush	1
22	10008017	切刀定位螺钉	Screw	1
23	10008016	剪刀	Knife	1
24	10005355	挡块销紧定螺钉 M3×8	Screw M3×3	1
25	10005313	挡块螺钉垫	Washer	1
26	10005033	转动螺钉 M4×4	Screw M4×4	1
27	10005553	挡块销	Pin	1
28	10005475	挡块	Plate	1
29	10003248	挡圈 Φ3	Collar	1
30	10005375	扭簧	Spring	1
31	10005459	螺钉 M4×8	Screw M4×8	1

11. 底板零件(1)

Bedplate psrts (1)

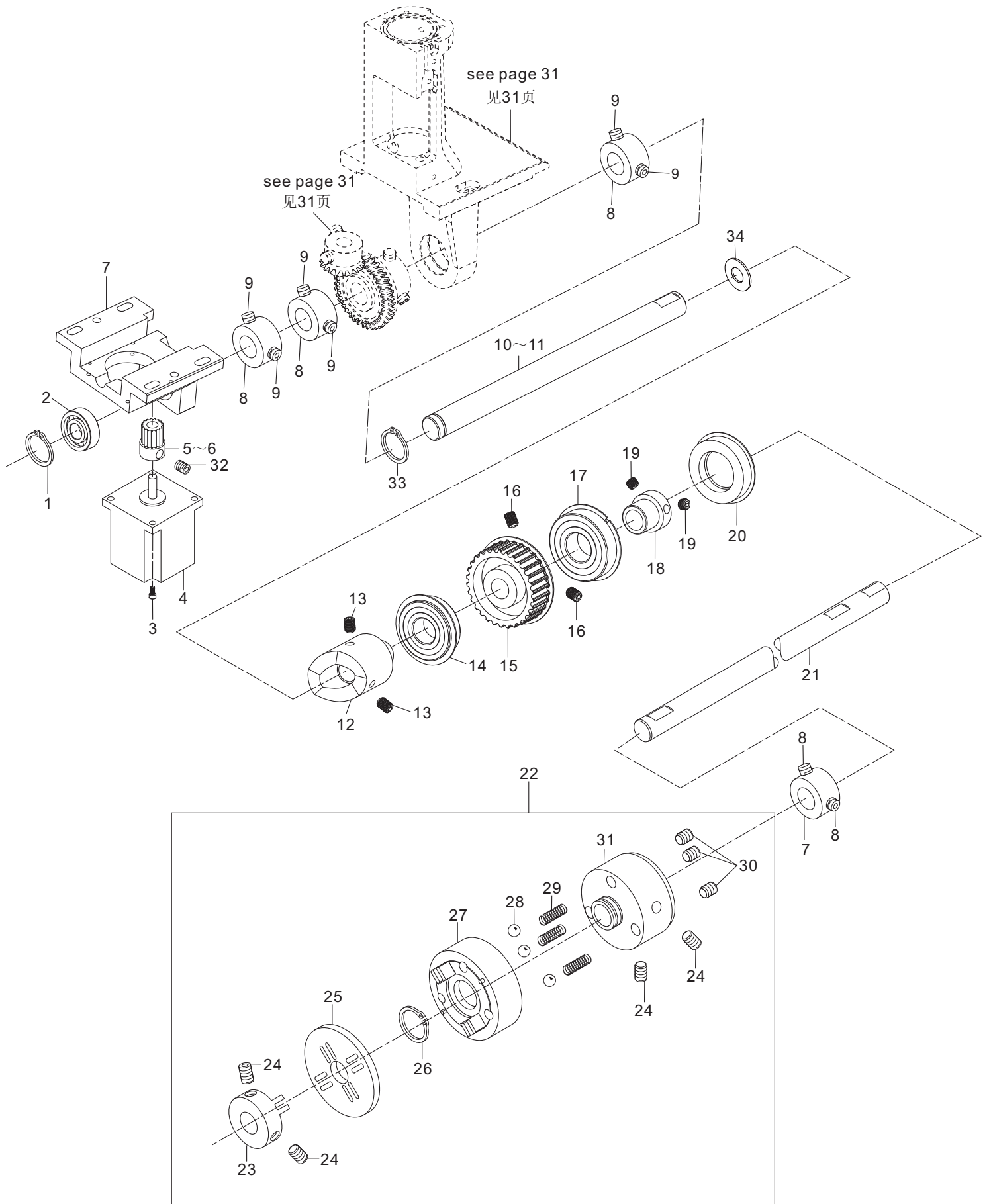

11. 底板零件 (1)

Bedplate parts (1)

序号 No.	件号 Part No.	名称	DESCRIPTION	数量 Qty
1	10005029	卡圈	Collar	1
2	10007200	轴承	Bearing	1
3	10005139	螺钉 M5×12	Screw M5×12	4
4	10062956	送料步进电机	Feeding stepping motor	1
5	10054591	送料带轮 (for 9630)	Feeding belt wheel (for 9630)	1
6	10054590	送料带轮 (for 9640)	Feeding belt wheel (for 9640)	1
7	10057356	下送料电机座	Below feeding motor support	1
8	10005409	12万向联接轴挡圈	Shaft collar	4
9	10012162	螺钉 M5×5	Screw M5×5	8
10	10038490	万向联接轴A (for 9630)	Universal coupling spindle A (for 9630)	1
11	10042082	双针万向联接轴 (for 9640)	Universal coupling spindle (for 9640)	1
12	10001509	下轴剪线凸轮	Thread trimming cam	1
13	10004938	螺钉 M6×0.75×8	Screw M6×0.75×8	2
14	10009787	轴承	Bearing	1
15	10041637	下轴宽带轮	Lower shaft sprocket	1
16	10009187	螺钉 M6×8	Screw M6×8	2
17	10007152	轴承	Bearing	1
18	20000511	下轴轴承套组件	Lower shaft rear bush	1
19	10005549	螺钉 M6×5	Screw M6×5	2
20	10041424	下轴胶塞	Rubber plug	1
21	10041426	一体下轴	Lower shaft	1
22	10005250	离合器	Clutch	1
23	10004969	离合器小连接组件	Clutch minor connector	1
24	10005300	螺钉 M6×0.75×8	Screw M6×0.75×8	4
25	10005364	离合器连接板	Clutch gusset	1
26	10005147	卡圈	Collar	1
27	10005189	离合器连接组件	Clutch connector	1
28	10013306	钢珠球	Steel ball	3
29	10004948	离合器小弹簧	Spring	3
30	10005119	螺钉 M6×0.75×6	Screw M6×0.75×6	3
31	10005486	离合器连接座	Clutch coupling	2
32	10011803	螺钉 M5×6	Screw M5×6	2
33	1005345	挡圈	Collar	1
34	10012782	垫圈	Washer	1

12. 底板零件(2)

Bedplate psrts (2)

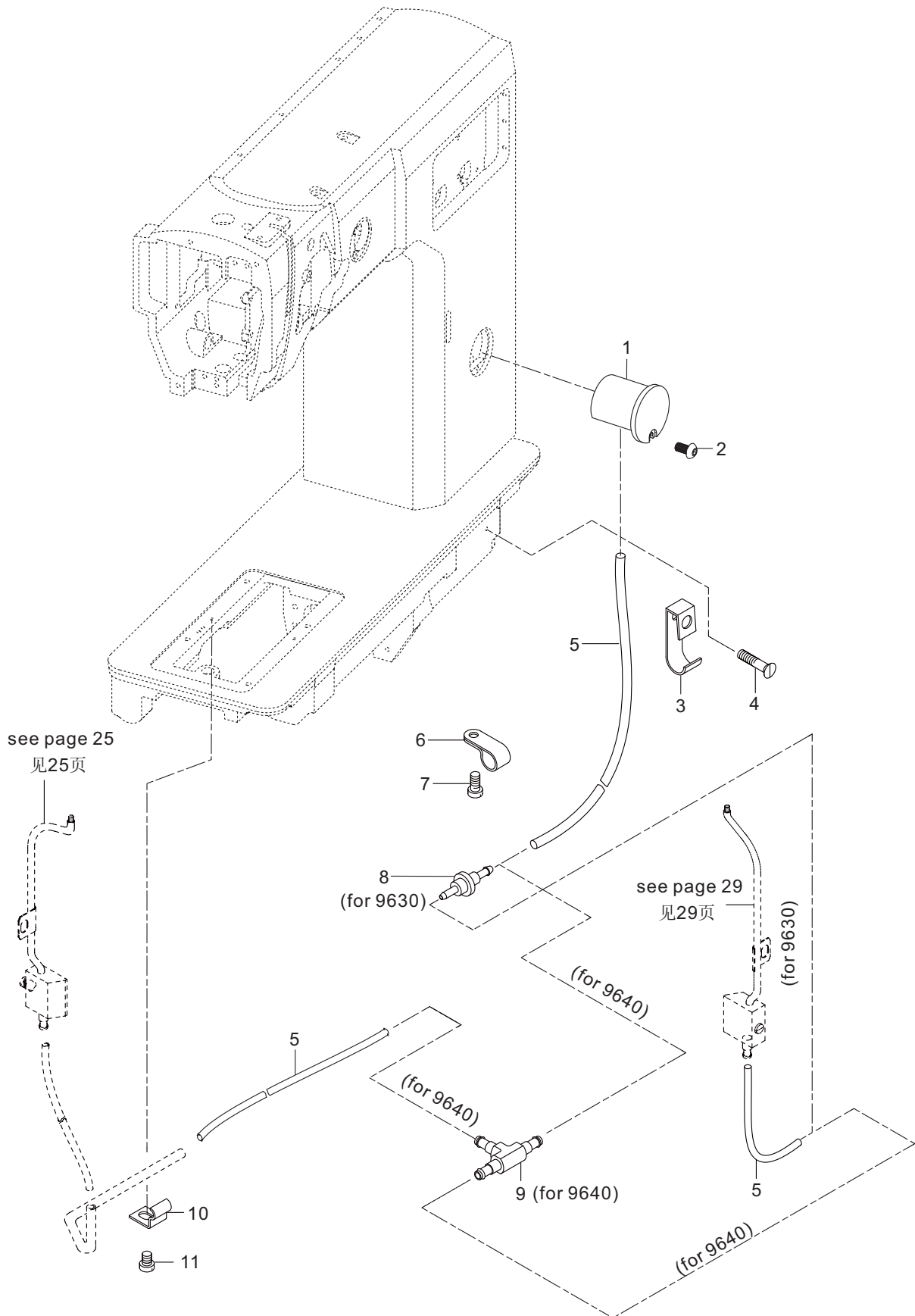

12. 底板零件 (2)

Bedplate parts (2)

序号 No.	件号 Part No.	名称	DESCRIPTION	数量 Qty
1	10041464	油窗组件	Oil tank assy	1
2	10005107	螺钉 M4×6	Screw M4×6	1
3	10004973	油管夹	Oil pipe clip	1
4	10041018	沉头螺钉 M4×14	Screw M4×14	1
5	10007800	油管	Oil tube	2
6	10008228	油管夹	Oil pipe clip	1
7	10005513	螺钉 M4×8	Screw M4×8	1
8	10005311	油管接头	Terminall	1
9	10001535	T形接头	Terminall	1
10	10002150	油管夹板	Oil tube support	1
11	10005076	螺钉 M4×5	Screw M4×5	1

13. 旋梭左支座(1)

Hook post, left(1)

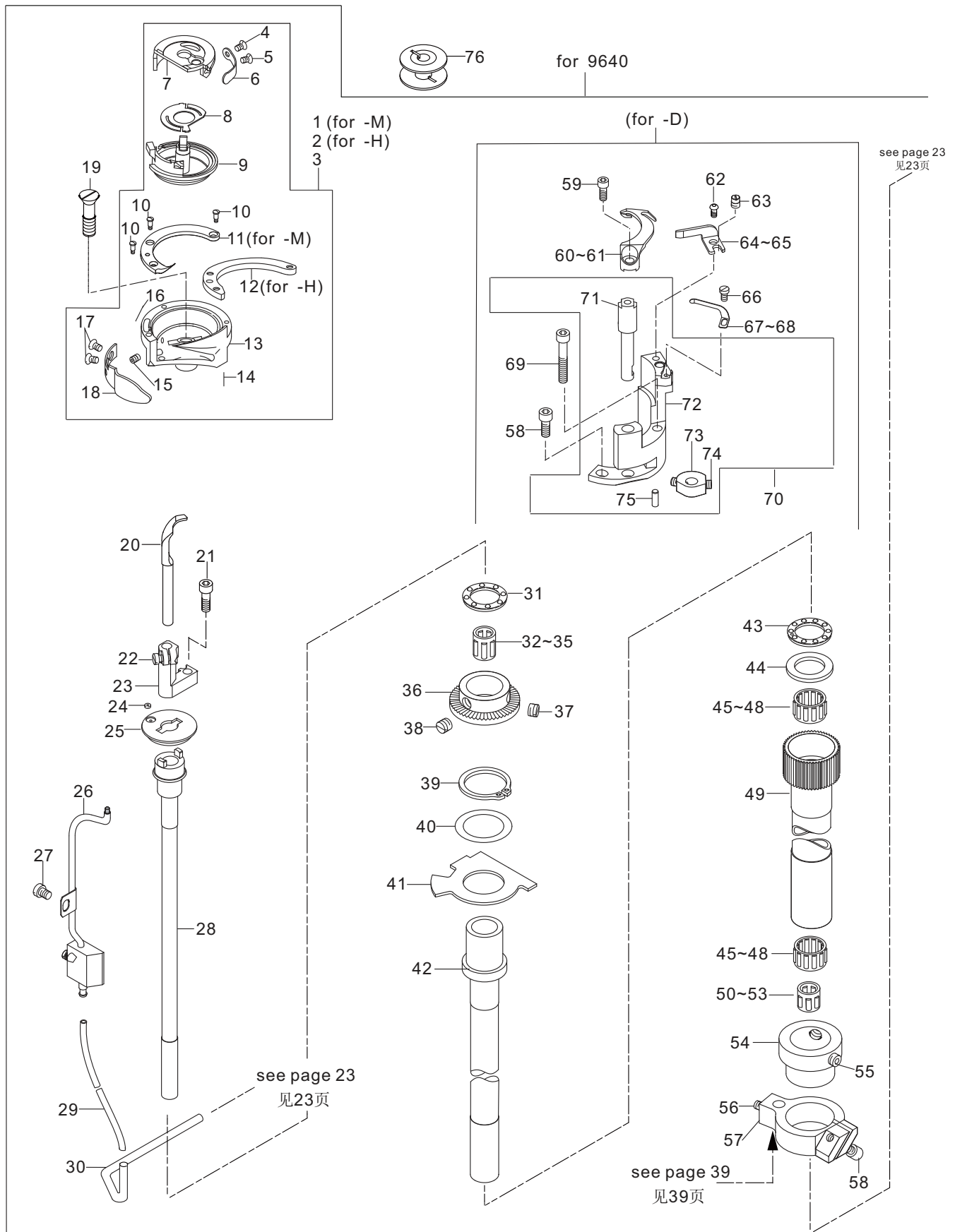

13. 旋梭左支座 (1)

Hook post, left (1)

序号 No.	件号 Part No.	名称	DESCRIPTION	数量 Qty
1	10005378	薄料旋梭 (for -M)	Hook-thin (for -M)	1
2	10069326	厚料旋梭 (for -H)	Hook-thickness (for -H)	1
3	10055263	进口旋梭	Hook (made in japan)	1
4	10004944	板式弹簧螺钉 I	Screw	1
5	10005206	板式弹簧螺钉 II	Screw	1
6	10005488	板式弹簧	Spring plate	1
7	10005555	梭头体	Hook-top	1
8	10005066	弹簧片	Spring	1
9	10005518	梭兜	Shuttle wan	1
10	10005541	螺钉	Screw	3
11	10005203	内梭头舌-薄料 (for -M)	Shuttle' tongue (for -M)	1
12	10005308	内梭头舌-厚料 (for -H)	Shuttle' tongue (for -H)	1
13	10005452	梭壳	Bobbin case	1
14	10005184	注塞	Wick	1
15	10005353	油毡注塞	Oil felt wick	1
16	10005354	螺钉 M3×4	Screw M3×4	1
17	10005106	螺钉 M2.6×4	M2.6×4	2
18	10005315	护针板	Needle protected plate	1
19	10004984	螺钉 M5×13	Screw M5×20	1
20	10005182	旋梭定位勾	Positioning finger	1
21	10005366	螺钉 M4×12	Screw M4×12	1
22	10005204	螺钉 M4×6	Screw M4×6	1
23	10005154	旋梭定位勾座	Positioning finger plate	1
24	10004937	O形圈	O ring	1
25	10005360	旋梭端盖	hook lid	1
26	10005394	油量调节组成	Rubber assy	1
27	10005076	螺钉 M4×5	Screw M4×5	1
28	10005245	旋梭传动芯轴	Hook transmission mandrel	1
29	10007800	油管	Oil felt	1
30	10002151	铜油管	Copper tubing	1
31	10005346	小端面轴承	Small end bearing	1
32	10007373	滚针轴承	Needle bearing	(1)
33	10007404	滚针轴承	Needle bearing	(1)
34	10007405	滚针轴承	Needle bearing	(1)
35	10007374	滚针轴承	Needle bearing	1
36	10001555	送料转盘	Feeding wheel	1
37	10001538	送料转盘螺钉 I M6×0.75×3	Screw M6×0.75×3	1
38	10001559	送料转盘螺钉 M6×.075×5	Screw M6×0.75×3	1
39	10001416	20旋梭护片卡圈	Collar	1
40	10001415	20旋梭护片垫圈	Collar	1
41	10001611	旋梭护片	Armor pieces	1
42	10001558	574送料传动轴	574 feeding drive shaft	1
43	10001556	574端面轴承	574 end bearing	1
44	10001560	端面轴承垫圈	Washer	1
45	10007759	滚针轴承	Needle bearing	2
46	10007758	滚针轴承	Needle bearing	(2)
47	10007757	滚针轴承	Needle bearing	(2)
48	10008054	滚针轴承	Needle bearing	(2)
49	10008234	574旋梭传动轴 I	574 hook shaft	1
50	10007368	滚针轴承	Needle bearing	(1)
51	10007367	滚针轴承	Needle bearing	1
52	10007199	滚针轴承	Needle bearing	1
53	10007198	滚针轴承	Needle bearing	1
54	10001887	20旋梭传动轴挡圈	Retaining ring	1
55	10005549	螺钉 M6×0.75×5	Screw M6×0.75×5	2
56	10012162	螺钉 M5×5	Screw M5×5	1
57	10001426	574旋梭传动曲柄	Crank	1
58	10012752	螺钉 M4×10	Screw M4×10	2
59	10005692	螺钉 M4×10	Screw M4×10	1
60	10039485	动刀 (台湾)	Movable knife (Made in Taiwan)	1
61	10038408	动刀 (国产)	Movable knife (Made in Chian)	(1)
62	10005107	螺钉 M4×6	Screw M4×6	1
63	10038411	偏心销	Eccentric pin	1
64	10039486	定刀 (台湾)	Fixed knife (Made in Taiwan)	1
65	10038410	定刀 (国产)	Fixed knife (Made in Chian)	1
66	10001512	螺钉 M2.5×3	Screw M2.5×3	1
67	10039487	线夹 (台湾)	Wire clip (Made in Taiwan)	1
68	10038412	线夹 (国产)	Wire clip (Made in Chian)	(1)
69	10001608	螺钉 M4×25	Screw M4×25	1
70	10038405	定刀支架部件	Moveble knife lever	1
71	10038407	勾线板支架A	Knife holder	1
72	10038406	定刀支架	Fixed knife bracket seat	1
73	10001517	传动齿轮	Transmission gear	1
74	10001514	螺钉 M4×4	Screw M4×4	2
75	10002069	定位销 3×10	Pin 3×10	1
76	10005461	梭心	Bobbin	1

14. 旋梭左支座(2) Hook post, left(2)

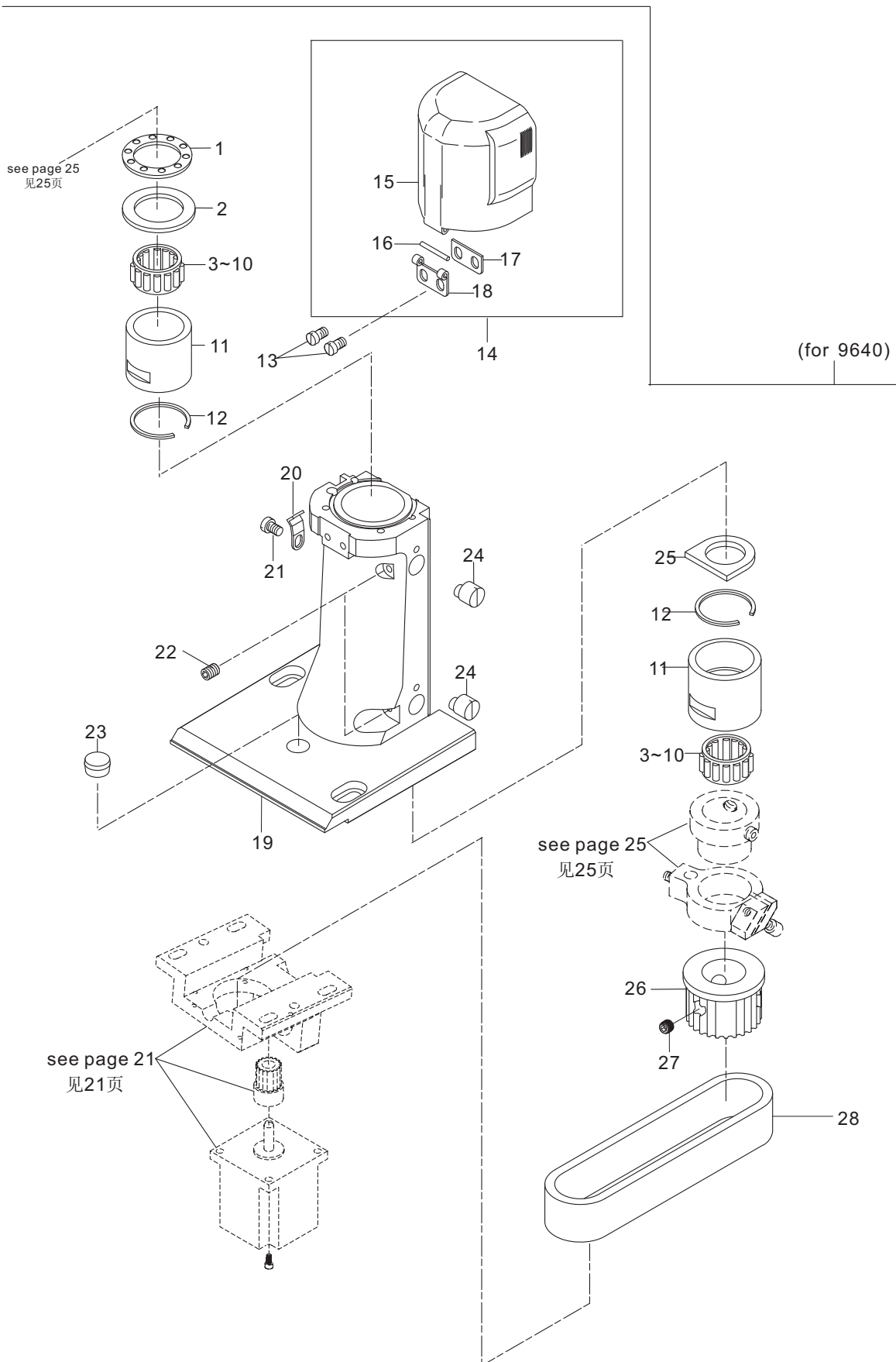

14. 旋梭左支座 (2)

Hook post, left (2)

序号 No.	件号 Part No.	名称	DESCRIPTION	数量 Qty
1	10005398	端面轴承	End bearing	1
2	10005052	垫圈	Washer	1
3	10005450	滚针轴承	Needle bearing	2
4	10006931	滚针轴承	Needle bearing	(2)
5	10006932	滚针轴承	Needle bearing	(2)
6	10006933	滚针轴承	Needle bearing	(2)
7	10007377	滚针轴承	Needle bearing	(2)
8	10007376	滚针轴承	Needle bearing	(2)
9	10007275	滚针轴承	Needle bearing	(2)
10	10007274	滚针轴承	Needle bearing	(2)
11	10005259	旋梭传动轴轴套	Hook shaft sleeve	2
12	10005383	挡圈	Collar	2
13	10005186	螺钉 M4×8	Screw M4×8	2
14	10038399	旋梭防护罩组件	Hook shield components	1
15	10038400	旋梭防护罩	Hook shield	1
16	10038404	销	Pin	1
17	10038403	垫片	Washer	1
18	10038402	护罩转动座	Shield driving seat	1
19	10057378	旋梭左支座E	Hook the left bearing	1
20	10004999	弹簧板	Spring plate	1
21	10005309	螺钉 M4×6	Screw M4×6	1
22	10009741	螺钉 M4×6	Screw M4×6	2
23	10005407	油塞	Oil plug	1
24	10005215	偏心销	Eccentric pin	2
25	10005177	油毡	Oil felt	1
26	10057352	双针电机带轮	Belt wheel	1
27	10057353	带轮螺钉M6×0.75	Screw M6×0.75	3
28	10057355	S3M同步带C	S3M Belt C	1

15. 旋梭右支座(1) Hook post, right(1)

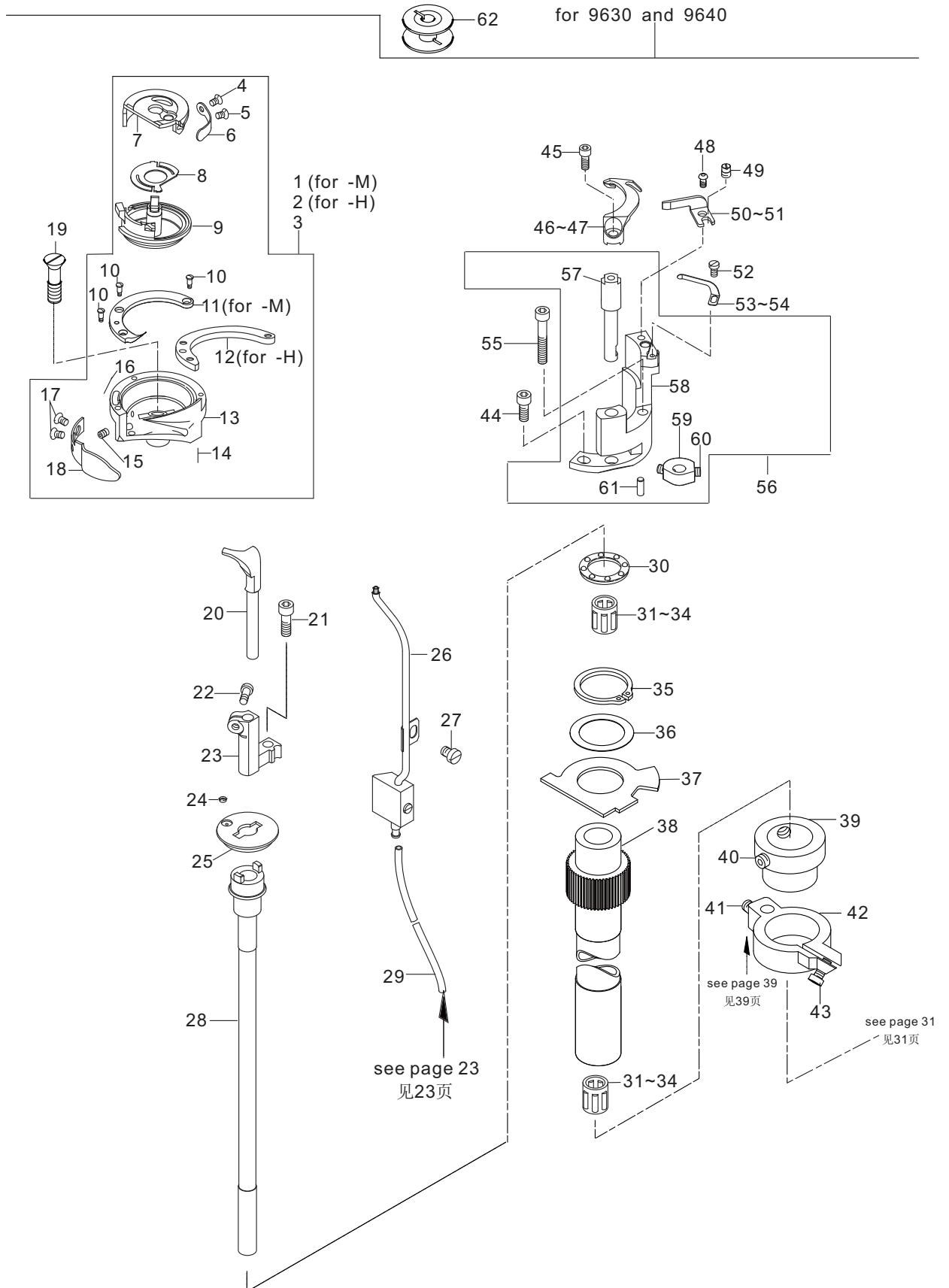

15. 旋梭右支座 (1)

Hook post, right (1)

序号 No.	件号 Part No.	名称	DESCRIPTION	数量 Qty
1	10005378	薄料旋梭 (for -M)	Hook-thin (for -M)	1
2	10069326	厚料旋梭 (for -H)	Hook-thickness (for -H)	1
3	10055263	进口旋梭	Hook (made in japan)	1
4	10004944	板式弹簧螺钉 I	Screw	1
5	10005206	板式弹簧螺钉 II	Screw	1
6	10005488	板式弹簧	Spring plate	1
7	10005555	梭头体	Hook-top	1
8	10005066	弹簧片	Spring	1
9	10005518	梭宛	Shuttle wan	1
10	10005541	螺钉	Screw	3
11	10005203	内梭头舌-薄料 (for -M)	Shuttle' tongue (for -M)	1
12	10005308	内梭头舌-厚料 (for -H)	Shuttle' tongue (for -H)	1
13	10005452	梭壳	Bobbin case	1
14	10005184	注塞	Wick	1
15	10005353	油毡注塞	Oil felt wick	1
16	10005354	螺钉 M3×4	Screw M3×4	1
17	10005106	螺钉 M2.6×4	M2.6×4	1
18	10005315	护针板	Needle protected plate	1
19	10056815	螺钉 M5×13	Screw M5×20	1
20	10005182	旋梭定位勾	Positioning finger	1
21	10005366	螺钉 M4×12	Screw M4×12	1
22	10005204	螺钉 M4×6	Screw M4×6	1
23	10005154	旋梭定位勾座	Positioning finger plate	1
24	10004937	O形圈	O ring	1
25	10005360	旋梭端盖	hook lid	1
26	10005394	油量调节组成	Rubber assy	1
27	10005076	螺钉 M4×5	Screw M4×5	1
28	10005245	旋梭传动芯轴	Hook transmission mandrel	1
29	10007800	油管	Oil felt	1
30	10005346	小端面轴承	End bearing	1
31	10007374	滚针轴承	Needle bearing	(2)
32	10007405	滚针轴承	Needle bearing	(2)
33	10007404	滚针轴承	Needle bearing	2
34	10007373	滚针轴承	Needle bearing	(2)
35	10003346	轴用挡圈	Collar	1
36	10001415	20旋梭护片垫圈	Washer	1
37	10001611	旋梭护片	Armor pieces	1
38	10001418	旋梭传动轴	hook shaft	1
39	10001887	20旋梭传动轴挡圈	Collar	1
40	10005549	螺钉 M6×0.75×5	Screw M6×0.75×5	2
41	10012162	螺钉 M5×5	Screw M5×5	1
42	10002106	旋梭传动曲柄	Crank	1
43	10012752	螺钉 M4×10	Screw M4×10	1
44	10012752	螺钉 M4×10	Screw M4×10	2
45	10005692	螺钉 M4×10	Screw M4×10	1
46	10039485	动刀 (台湾)	Movable knife (Made in Taiwan)	1
47	10038408	动刀 (国产)	Movable knife (Made in Chian)	(1)
48	10005107	螺钉 M4×6	Screw M4×6	1
49	10038411	偏心销	Eccentric pin	1
50	10039486	定刀 (台湾)	Fixed knife (Made in Taiwan)	1
51	10038410	定刀 (国产)	Fixed knife (Made in Chian)	1
52	10001512	螺钉 M2.5×3	Screw M2.5×3	1
53	10039487	线夹 (台湾)	Wire clip (Made in Taiwan)	1
54	10038412	线夹 (国产)	Wire clip (Made in Chian)	(1)
55	10001608	螺钉 M4×25	Screw M4×25	1
56	10038405	定刀支架部件	Moveble knife lever	1
57	10038407	勾线板支架A	Knife holder	1
58	10038406	定刀支架	Fixed knife bracket seat	1
59	10001517	传动齿轮	Transmission gear	1
60	10001514	螺钉 M4×4	Screw M4×4	2
61	10002069	定位销 3×10	Pin 3×10	1
62	10005461	梭心	Bobbin	1

16. 旋梭右支座(2) Hook post, right(2)

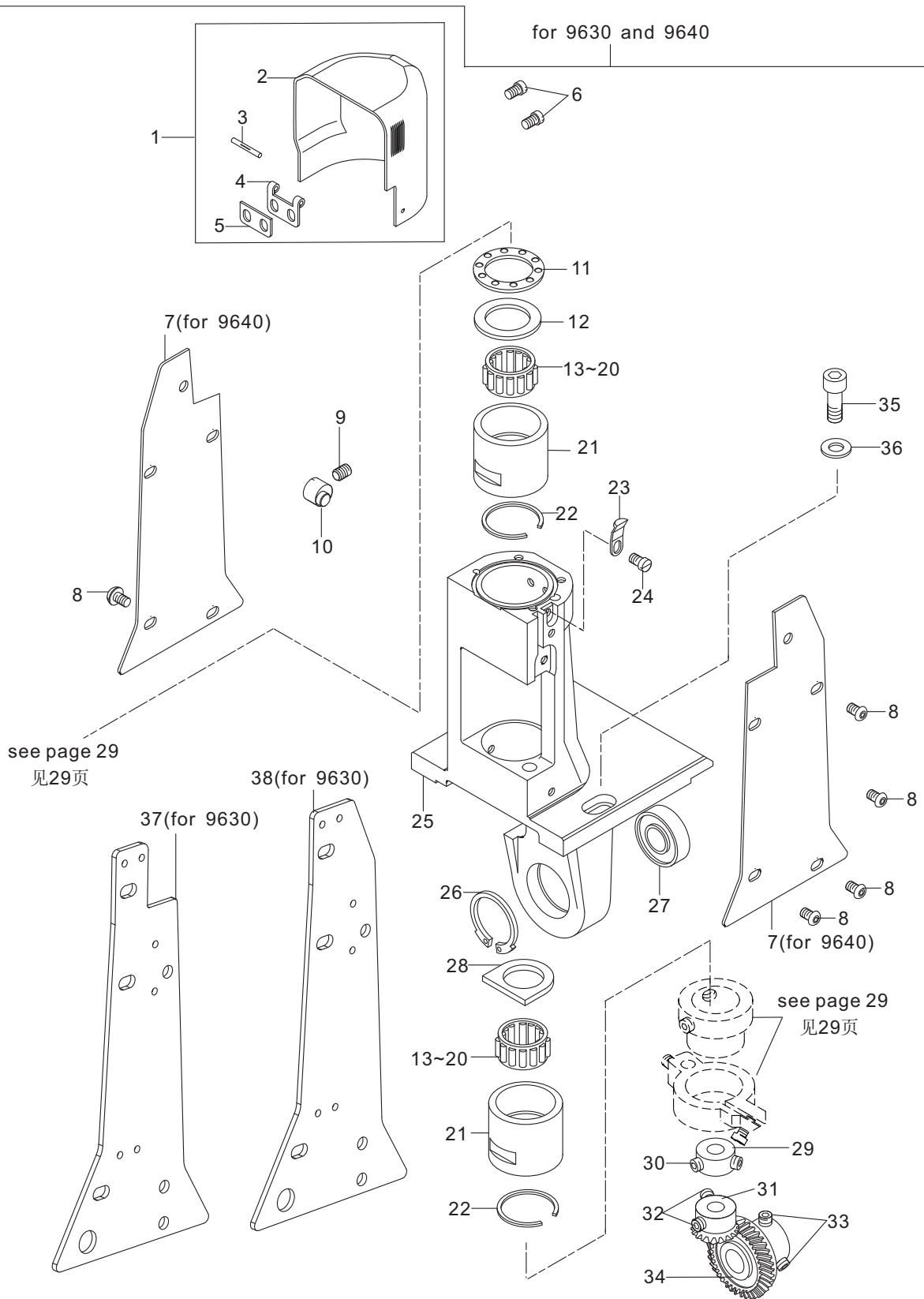

16.旋梭右支座 (2)

Hook post, right (2)

序号 No.	件号 Part No.	名称	DESCRIPTION	数量 Qty
1	10038399	旋梭防护罩组件	Hook shield components	1
2	10038400	旋梭防护罩	Hook shield	1
3	10038404	销	Pin	1
4	10038402	护罩转动座	Shield driving seat	1
5	10038403	垫片	Washer	1
6	10005186	螺钉 M4×8	Screw M4×8	2
7	20013284	双针侧盖板喷漆 (for 9640)	Double needle plate measuring (for 9640)	2
8	10005107	螺钉 M4×6	Screw M4×6	10
9	10009741	螺钉 M4×6	Screw M4×6	2
10	10005215	偏心销	Eccentric pin	2
11	10005398	端面轴承	End bearing	1
12	10005052	21垫圈	Washer	1
13	10005450	滚针轴承	Needle bearing	2
14	10006931	滚针轴承	Needle bearing	(2)
15	10006932	滚针轴承	Needle bearing	(2)
16	10006933	滚针轴承	Needle bearing	(2)
17	10007377	滚针轴承	Needle bearing	2
18	10007376	滚针轴承	Needle bearing	(2)
19	10007275	滚针轴承	Needle bearing	(2)
20	10007274	滚针轴承	Needle bearing	(2)
21	10005259	旋梭传动轴轴套	Hook shaft sleeve	2
22	10005383	挡圈	Collar	2
23	10004999	弹簧板	Spring plate	1
24	10005309	螺钉 M4×6	Screw M4×6	1
25	20003491	旋梭支座喷漆	Hook the right bearing	1
26	10005029	28挡圈	Collar	1
27	10007200	轴承 6001ZZ	Bearing 6001ZZ	1
28	10005177	油毡	Oil felt	1
29	10005413	8旋梭传动芯轴挡圈	Collar	1
30	10005549	螺钉 M6×0.75×5	Screw M6×0.75×5	2
31	10006298	旋梭传动齿轮 II	The hook driving gear II	1
32	10005258	螺钉 M6×0.75×5	Screw M6×0.75×5	2
33	10005119	螺钉 M6×0.75×6	Screw M6×0.75×6	2
34	10006297	旋梭传动齿轮 I	The hook driving gear I	1
35	10009008	螺钉 M6×16	Screw M6×16	4
36	10005550	垫圈 Φ6	Washer Φ6	4
37	20013282	单针侧盖板A喷漆 (for 9630)	One needle plate measuring (for 9630)	1
38	20003490	侧盖板I (for 9630)	Plate measuring (for 9630)	1

17. 送料支座

Feed wheel post, left

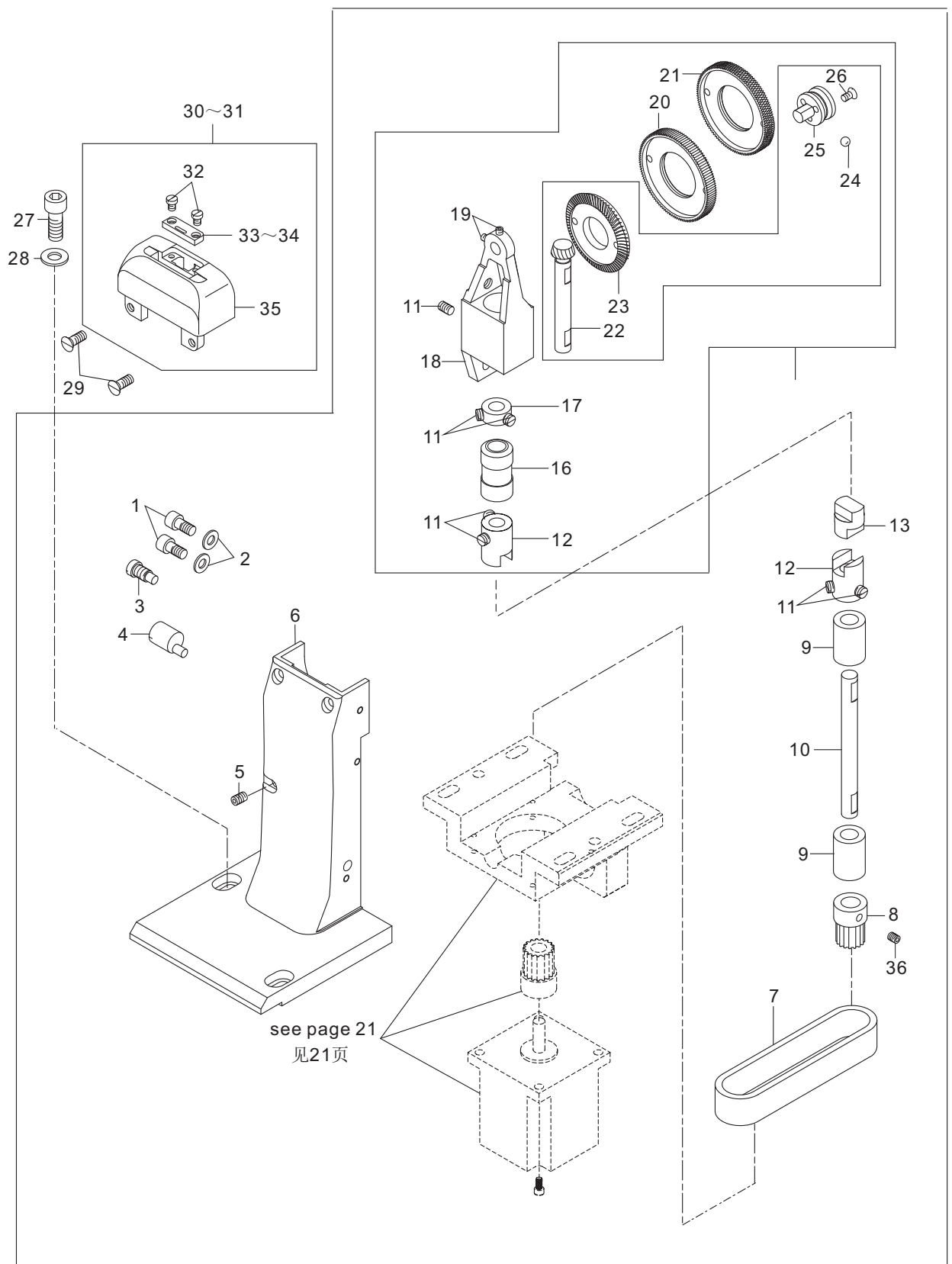

17.送料支座

Feed wheel post , left

序号 No.	件号 Part No.	名称	DESCRIPTION	数量 Qty
1	10005139	螺钉 M5×12	Screw M5×12	2
2	10005016	垫圈 Φ5	Washer Φ5	2
3	10004978	螺钉 M6×8	Screw M6×8	1
4	10005257	偏心销	Pin	1
5	10009741	螺钉 M4×6	Screw M4×6	1
6	20021226	送料支座E喷漆	Feeding support E paint	1
7	10054593	S3M传送带B	S3M Conveyor B	1
8	10054590	Φ7电机带轮	Belt wheel Φ7	1
9	10005431	套	Axle sleeve	2
10	10005402	送料传动轴	Feeding transmission shaft	1
11	10012162	螺钉 M5×5	Screw M5×5	7
12	10005236	联接衬套	Coupling bushing	2
13	10005084	联接块	Connecting block	1
14	10005376	送料机构组件（直齿送料轮）	Straight tooth feeding mechanism	1
15	10043255	滚花送料机构组件（滚花送料轮）	Knurling tooth feeding mechanism	(1)
16	10005082	送料机构座前轴套	Axle sleeve	1
17	10005310	送料传动锥齿轮挡圈	Collar	1
18	10005185	送料机构座	Feeding mechanism of bearing	1
19	10005354	螺钉 M3×4	Screw M3×4	2
20	10005037	送料盘（直齿送料轮）	Feeding straight tooth	1
21	10043256	滚花送料盘（滚花送料轮）	Knurling tooth feed tray	(1)
22	10005071	送料传动锥齿轮 I	The feed driving bevel gear I	1
23	10005117	送料传动锥齿轮 II	The feed driving bevel gear II	1
24	10006178	钢球 Φ2	Steel ball Φ2	23
25	10028364	送料齿联接块组件	The Connecting block assembly	1
26	10005348	螺钉 M2.5×4	Screw M2.5×4	3
27	10009008	螺钉 M6×16	Screw M6×16	2
28	10003324	垫圈 Φ6	Washer Φ6	2
29	10005459	螺钉 M4×8	Screw M4×8	2
30	10055259	单针针板组件（-M）	Single needle plate assembly（-M）	1
31	10055260	单针针板组件（-H）	Single needle plate assembly（-H）	(1)
32	10003903	针板螺钉 M2×3	Screw M2×3	2
33	10055257	小针板-薄料（for -M）	Small needle plate -thin material（for -M）	1
34	10055258	小针板-厚料（for -H）	Small needle plate -thick material（for -H）	(1)
35	10053427	针板罩S	Needle plate seat S	1
36	10011803	螺钉 M5×6	Screw M5×6	2

18. 送料轮托盘

Feed wheel mounting plate

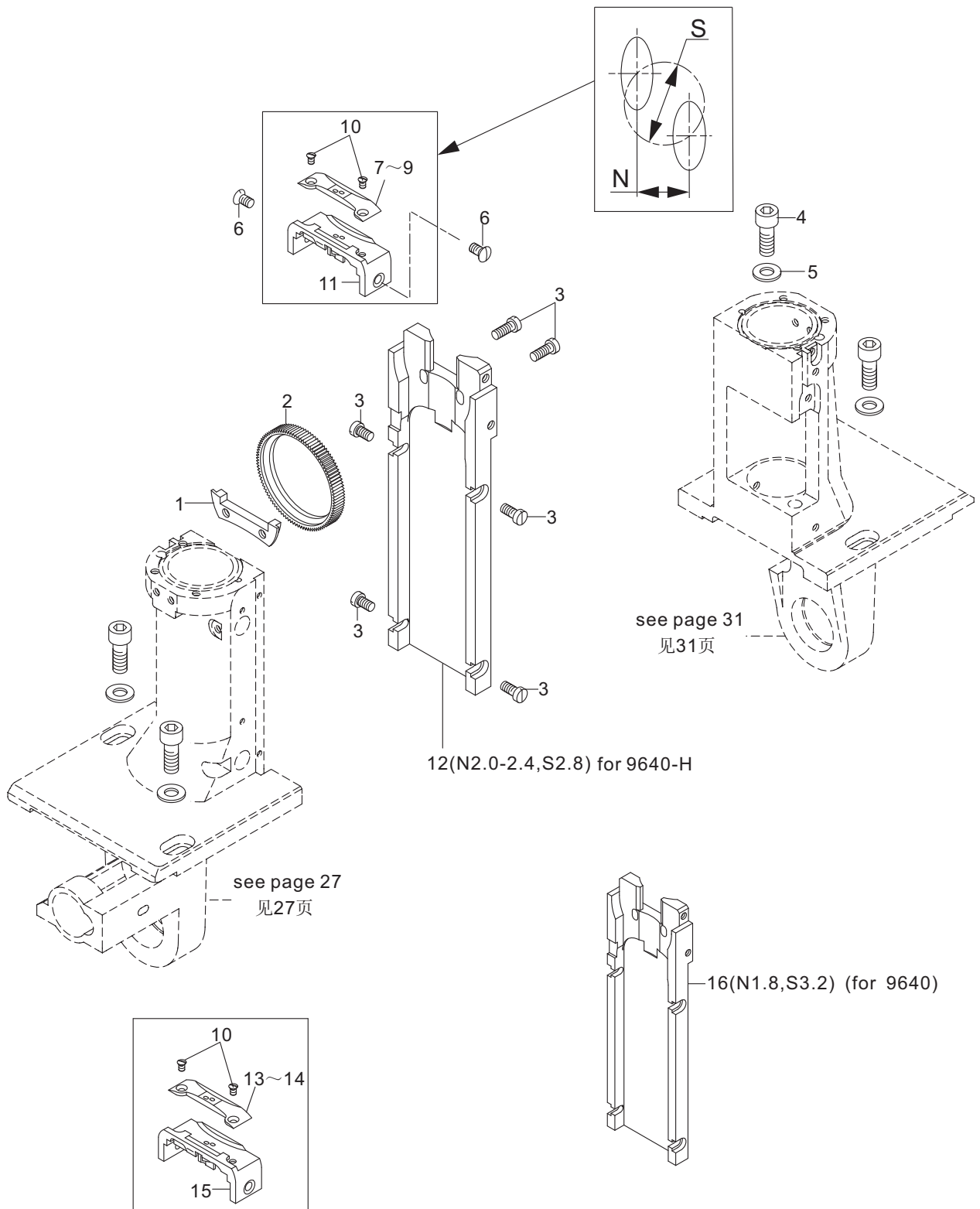

18.送料轮托盘

Feed wheel mounting plate

序号 No.	件号 Part No.	名称	DESCRIPTION	数量 Qty
1	10030181	送料轮调整块	Feeding wheel adjusting block	1
2	10030180	送料轮	Feeding wheel	1
3	10001580	螺钉 M4×10	Screw M4×10	6
4	10009008	螺钉 M6×16	Screw M6×10	4
5	10005550	垫圈 Φ6	Washer Φ6	4
6	10002545	螺钉 M4×6	Screw M4×6	2
7	10051304	双针小针板(N1.2-1.8,S2.8)	Small double needle plate(N1.2-1.8)	1
8	10051305	双针小针板(N2.0-2.4,S2.8)	Small double needle plate(N2.0-2.4)	(1)
9	10060561	双针小针板(N2.2-2.6,S2.8)	Small double needle plate(N2.0-2.6)	(1)
10	10049413	双针针板固定螺钉 M3×3.2	Screw M3×3.2	2
11	10051303	针板罩(N2.0-2.4,S2.8)	Double needle plate cover(N2.0-2.4)	1
12	10043208	针板罩座(N2.0-2.4,S2.8)	Double needle plate cover seat(N2.0-2.4)	1
13	10001383	双针小针板(N1.8,S3.2) for -M	Small double needle plate(N1.8)	(1)
14	10030579	双针小针板(N1.8,S3.2) for -H	Small double needle plate(N1.8)	(1)
15	10041325	针板罩 (N1.8,S3.2)	Double needle plate cover(N1.8)	(1)
16	10001388	针板罩座 (N1.8,S3.2)	Double needle plate cover seat (N1.8)	(1)

19. 剪线结构(-D) Thread trimmer (-D)

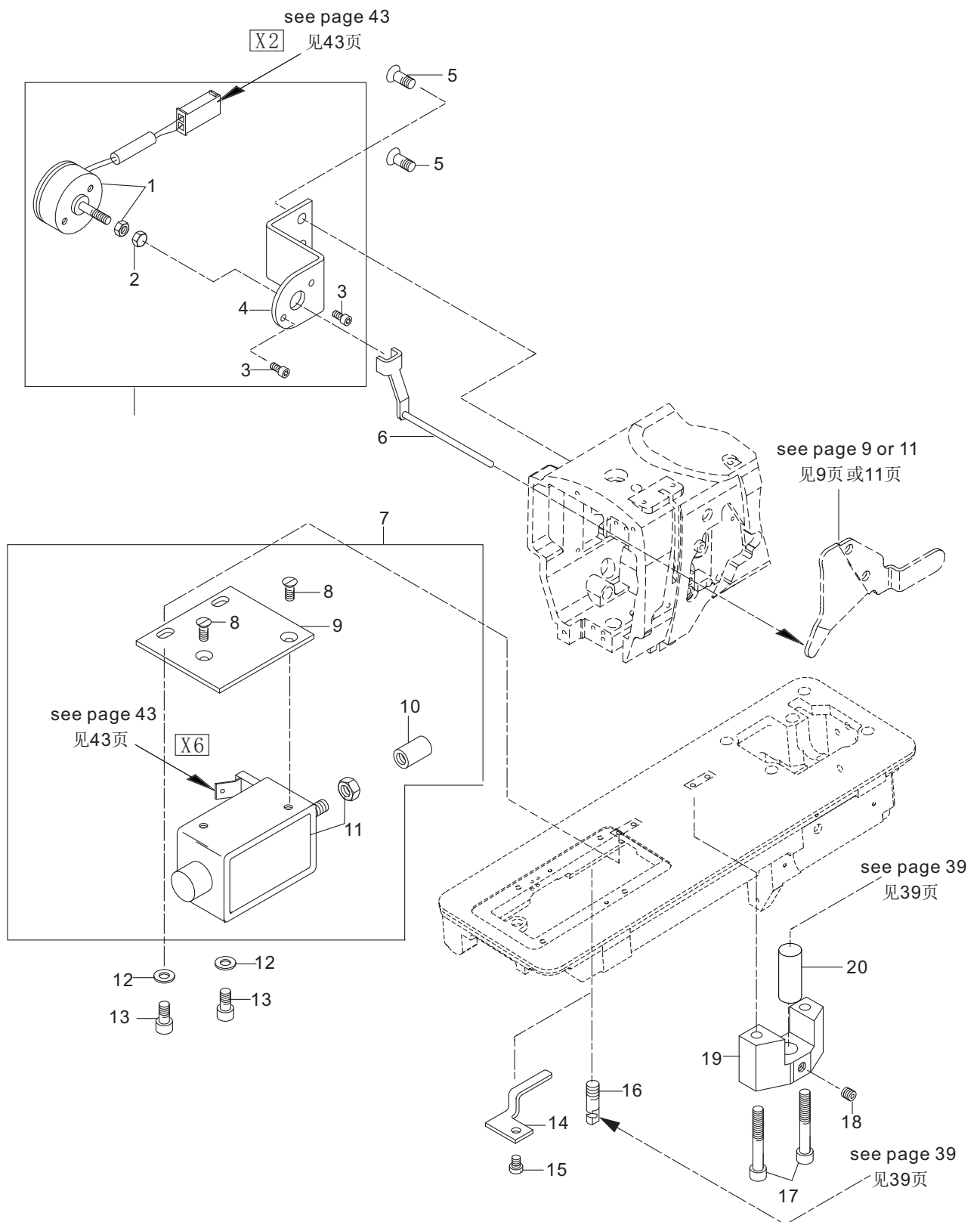

19.剪线结构 (-D)

Thread trimmer (-D)

序号 No.	件号 Part No.	名称	DESCRIPTION	数量 Qty
1	10001510	松线电磁铁	Loose line electromagnet	1
2	10001511	挺线电磁铁帽 M4	Nut M4	1
3	10002129	螺钉 M3×5	Screw M3×5	2
4	10001506	松线电磁铁安装板	Mounting plate	1
5	10001948	螺钉 M5×10	Screw M5×10	2
6	10001657	电磁铁挺线钉	Tension release pin	1
7	10006402	剪线电磁铁整组	Shear line electromagnet assembly	1
8	10008233	螺钉 M4×6	Screw M4×6	2
9	10001502	剪线电磁铁安装板	Mounting plate	1
10	10001614	剪线电磁铁联接节	Connecting block	1
11	10001499	剪线电磁铁	Shear line electromagnet	1
12	10005016	垫圈 Φ5	Washer Φ5	2
13	10010953	螺钉 M5×10	Screw M5×10	2
14	10001508	油线挡板	Oil line baffle	1
15	10005076	螺钉 M4×5	Screw M4×5	1
16	10005318	螺钉 M6×8	Screw M6×8	1
17	10001497	螺钉 M5×30	Screw M5×30	2
18	10012162	螺钉 M5×5	Screw M5×5	1
19	10002142	剪线摆动杆座	Shear line swing rod seat	1
20	10001498	剪线摆动杆座销 10×32	Pin 10×32	1

20. 剪线结构(-D) Thread trimmer (-D)

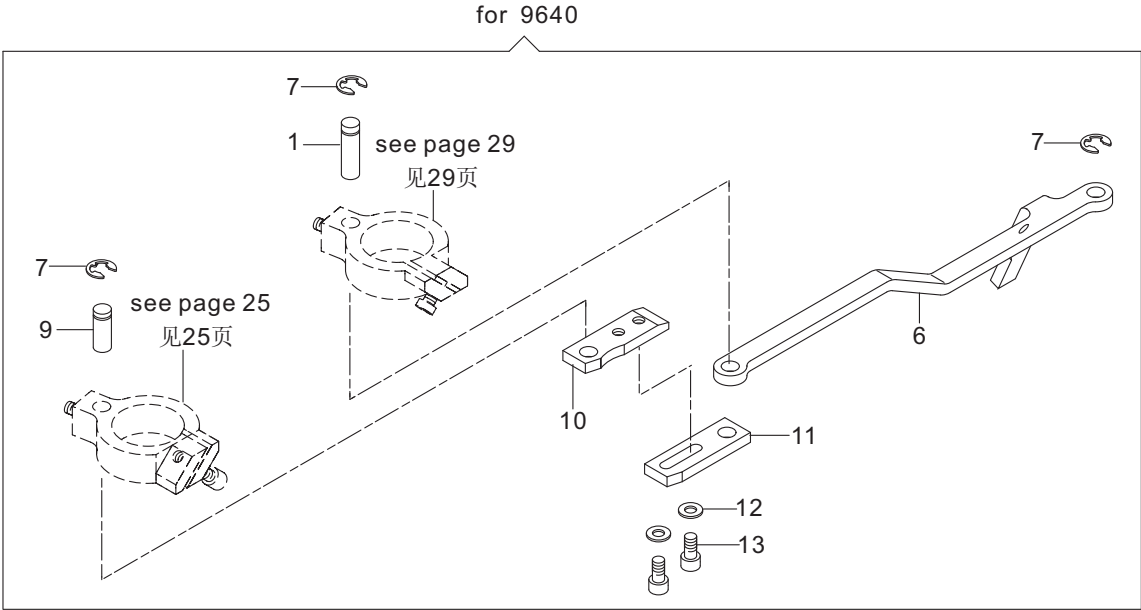
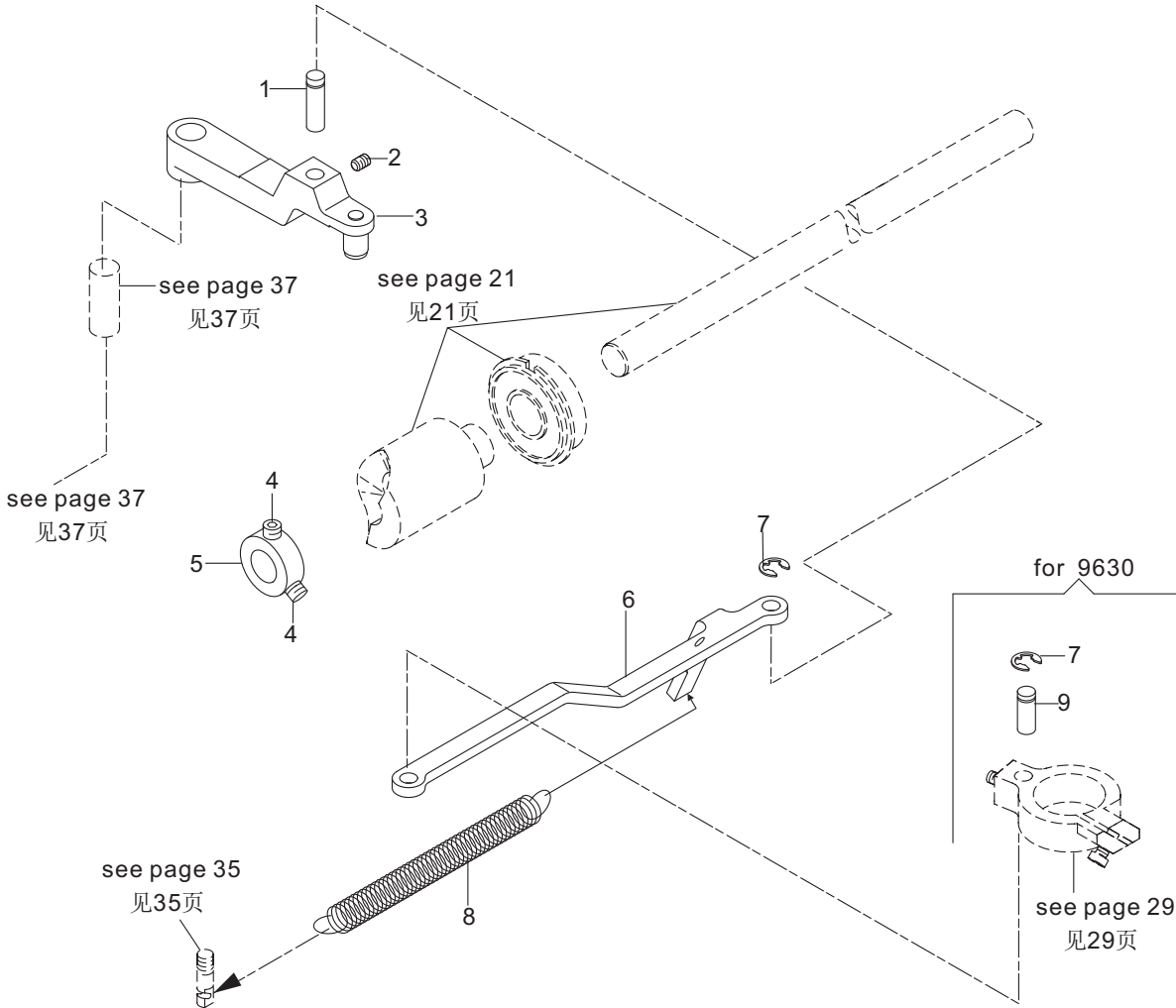

20.剪线结构 (-D)

Thread trimmer (-D)

序号 No.	件号 Part No.	名称	DESCRIPTION	数量 Qty
1	10001501	剪线摆动杆销	Pin	2
2	10012162	螺钉 M5×5	Screw M5×5	1
3	10001503	剪线摆动杆组件	Swing rod assembly	1
4	10012162	螺钉 M5×5	Screw M5×5	2
5	10005409	12万向联接轴挡圈	Retaining ring	1
6	10001504	剪线摆动拉杆	Shear line swing rod	1
7	10001947	剪线摆动杆销卡圈	Collar	3
8	10001946	剪线摆动拉杆弹簧	Spring	1
9	10001505	剪线摆动销	Pin	2
10	10002201	剪线摆动拉杆连接板 II	Connecting plate II	1
11	10001722	剪线摆动拉杆连接板 I	Connecting plate I	1
12	10005260	垫圈 Φ4	Washer Φ4	2
13	10005350	螺钉 M4×8	Screw M4×8	2

21. 自动抬压脚

Automatic presser foot lifter

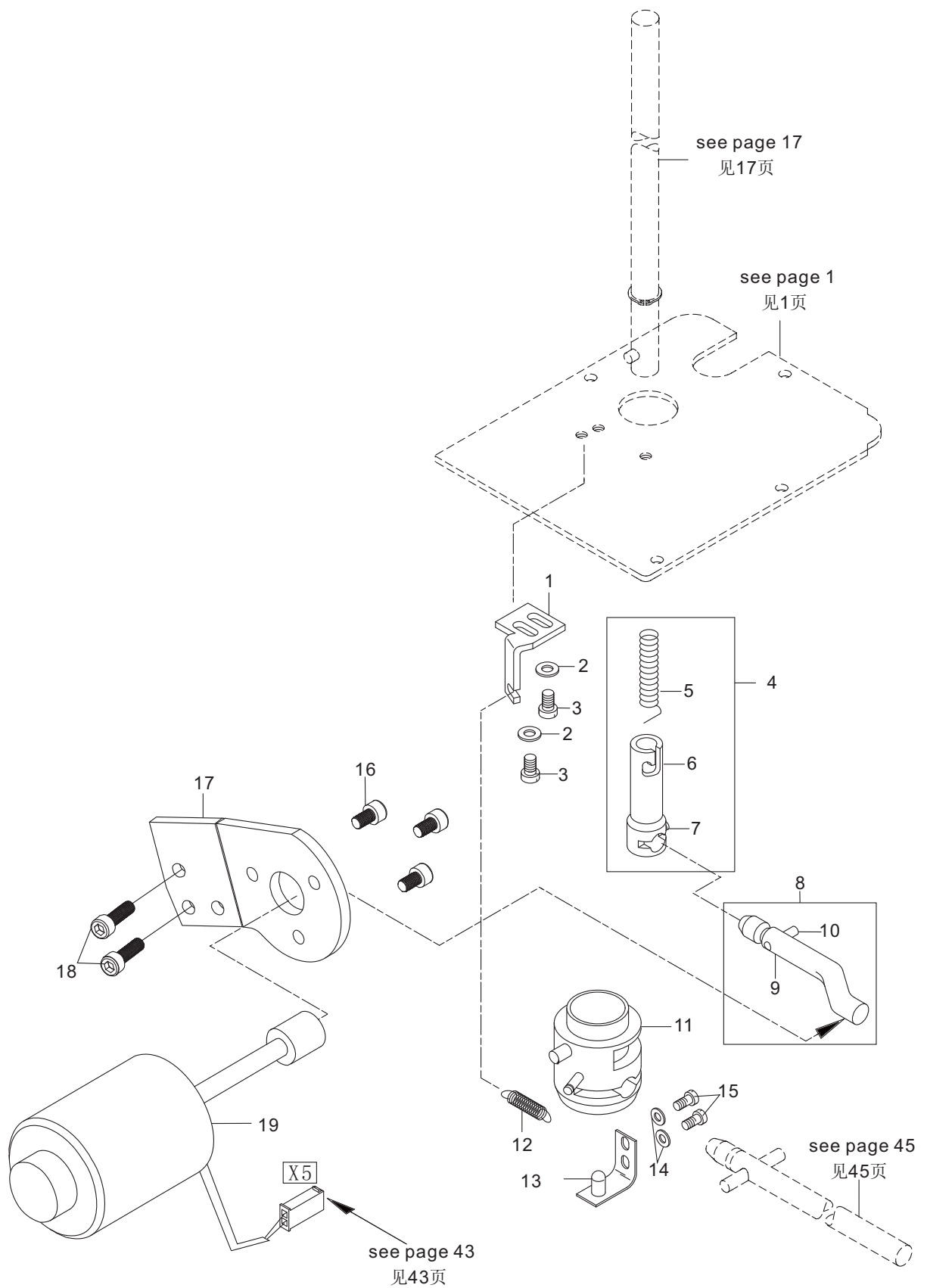

21.自动抬压脚 Automation presser foot lifter

序号 No.	件号 Part No.	名称	DESCRIPTION	数量 Qty
1	10001489	操纵顶柱复位板	Reset plate	1
2	10005260	垫圈 Φ4	Washer Φ4	2
3	10010953	螺钉 M5×10	Screw M5×10	2
4	10005514	操纵顶柱组件	Manipulating the top column assembly	1
5	10005158	操纵顶柱弹簧	Spring	1
6	10005053	操纵顶柱	Manipulating of the top pillar	1
7	10009741	螺钉 M4×6	Screw M4×6	1
8	10002145	操纵弯杆组件	Control rod bending component	1
9	10002146	操纵弯杆	Control rod bending	1
10	10001487	操作弯杆销 4×16	Pin	1
11	10001453	脚膝抬压脚操作顶柱组件	Presser foot lifting component of knee	1
12	10002144	复位弹簧	Spring	1
13	10001450	操纵弯杆挡片组件	Baffle assembly	1
14	10005260	垫圈 Φ4	Washer Φ4	2
15	10005204	螺钉 M4×6	Screw M4×6	2
16	10005122	螺钉 M6×10	Screw M6×10	3
17	10001802	中间板	Mounting plate	1
18	10002028	螺钉 M6×20	Screw M6×20	2
19	10041477	一体机压脚电磁铁	Presser foot lifting electromagnet	1

22. 电控 Electronic control

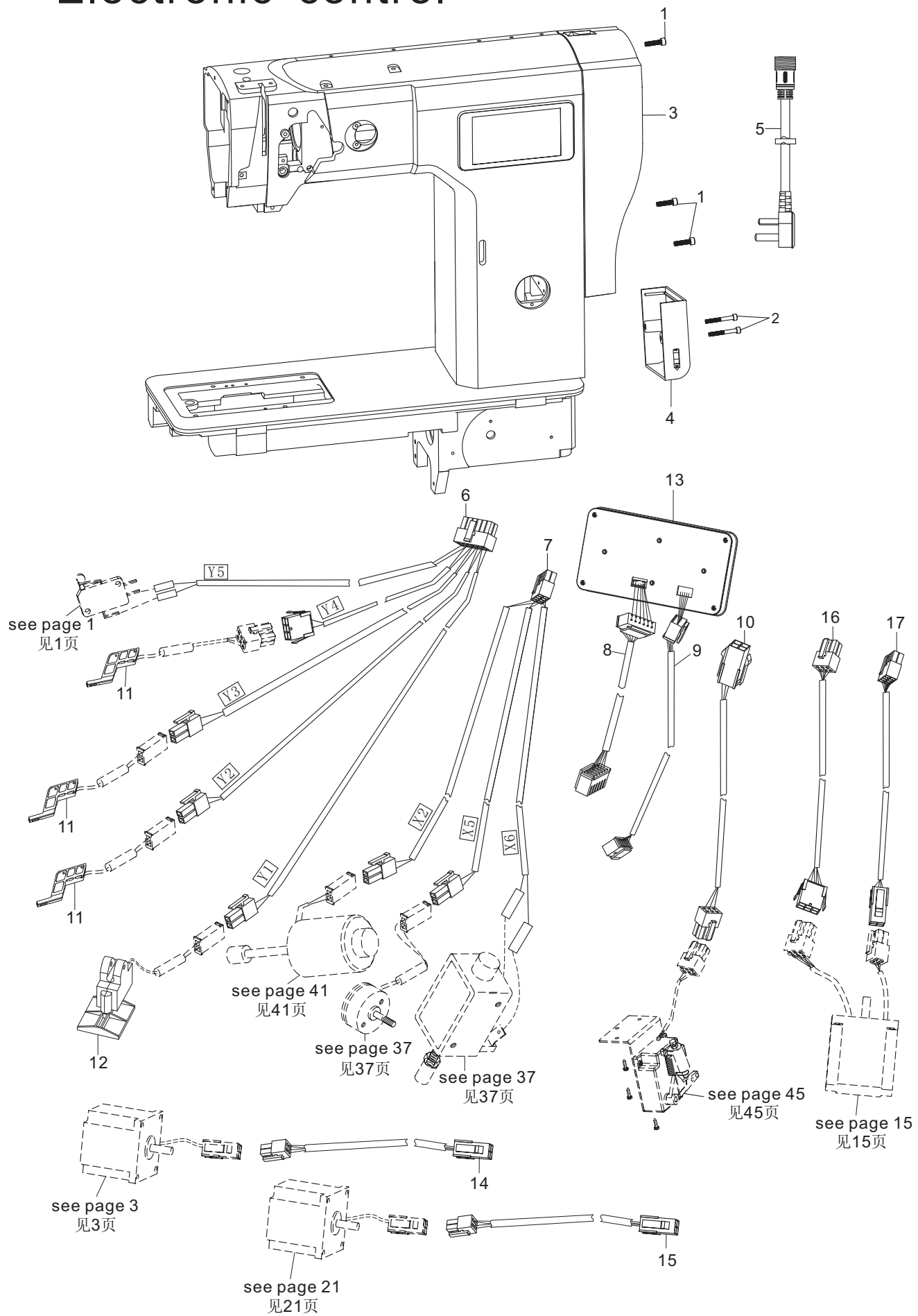

22. 电控

Electric control

序号 No.	件号 Part No.	名称	DESCRIPTION	数量 Qty
1	10003100	螺钉 M5×35	Screw M5×35	3
2	10003141	螺钉 M5×20	Screw M5×20	4
3	10061329	步进电控	Electronic control	1
4	10062455	电控下罩盖	Cover	1
5	10052822	电源转接线	The power adapter cable	1
6	10062962	机头灯转接线	Head lamp adapte	1
7	10062961	步进电磁铁线	Stepping electromagnet line	1
8	10062963	面板烧录转接线	Panel burn switch line	1
9	10062964	面板选针盒转接线	Panel needle selection box switch line	1
10	10062965	踏板转接线	Redal switch line	1
11	10061239	机头灯组件	Head lamp subassembly	1
12	20022622	点动膝控组件	Inching switch by keen	1
13	10063214	液晶面板	LCD panel	1
14	10062957	上送料步进转接线	Upper feeding stepping motor switch line	1
15	10062958	下送料步进转接线	Nether feeding stepping motor switch line	1
16	10062960	摆针步进编码器线	Stepping motor encoder line	1
17	10062959	摆针步进转接线	Stepping motor switch line	1

23. 附件(1)

Accessories components (1)

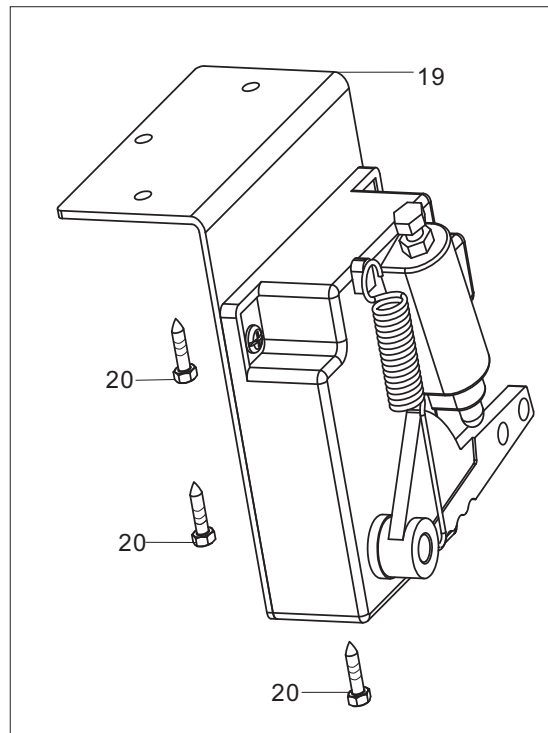
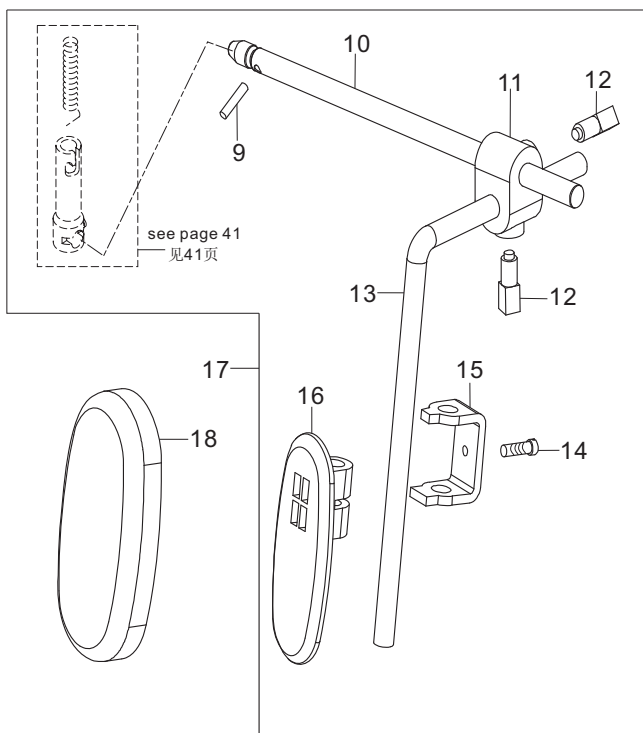
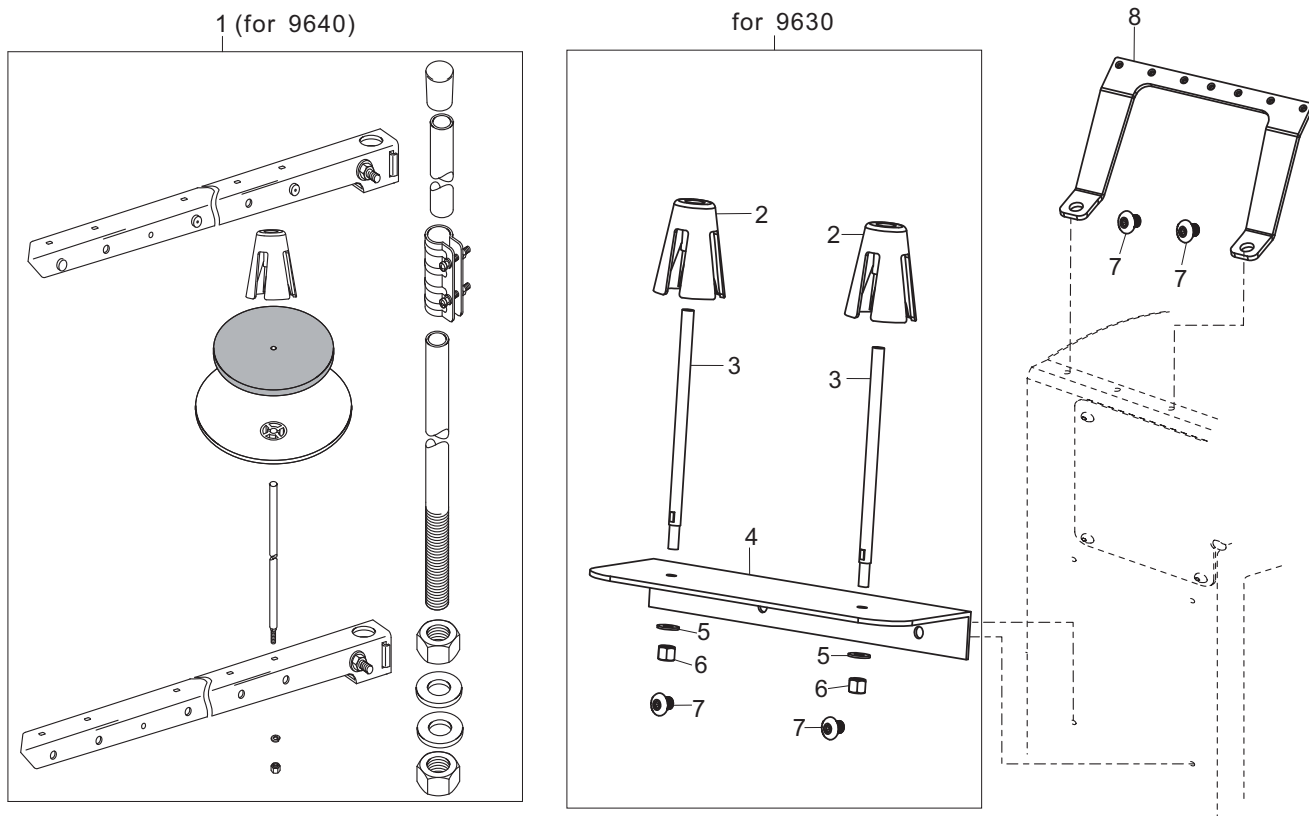

23.附件 (1) Accessories components (1)

序号 No.	件号 Part No.	名称	DESCRIPTION	数量 Qty
1	10006300	三线线架 (for 9640)	Three wire frame component	1
2	10004287	线盘塑料压块	Wire disc plastic pressing block	2
3	10041472	线架轴	Wire rack shaft	2
4	10041471	线盘支架	Wire coil bracket	1
5	10009207	垫片 Φ5	Washer Φ5	2
6	10002953	螺母 M5	Nut M5	2
7	10007096	螺钉 M5×10	Screw M5×10	2
8	10041470	过线架	Lead wire frame	1
9	10005193	销 4×18	Pin 4×18	1
10	10005045	操纵连杆	Control rod	1
11	10005199	操纵杆接头	Control rod joints	1
12	10005234	螺钉 M8×14	Screw M8×14	2
13	10005213	操纵杆	Control stick	1
14	10005421	螺钉 M5×13.3	Screw M5×13.3	1
15	10005273	膝控调节支架	Knee control adjusting bracket	1
16	10005115	膝控操纵架	Knee control frame	1
17	10004975	膝控组件	Knee control assembly	1
18	10005455	膝控软垫	Knee control pad	1
19	10048219	踏板	Pedal	1
20	10048223	踏板螺钉	Self tapping Screw	3

24. 附件(2)

Accessories components (2)

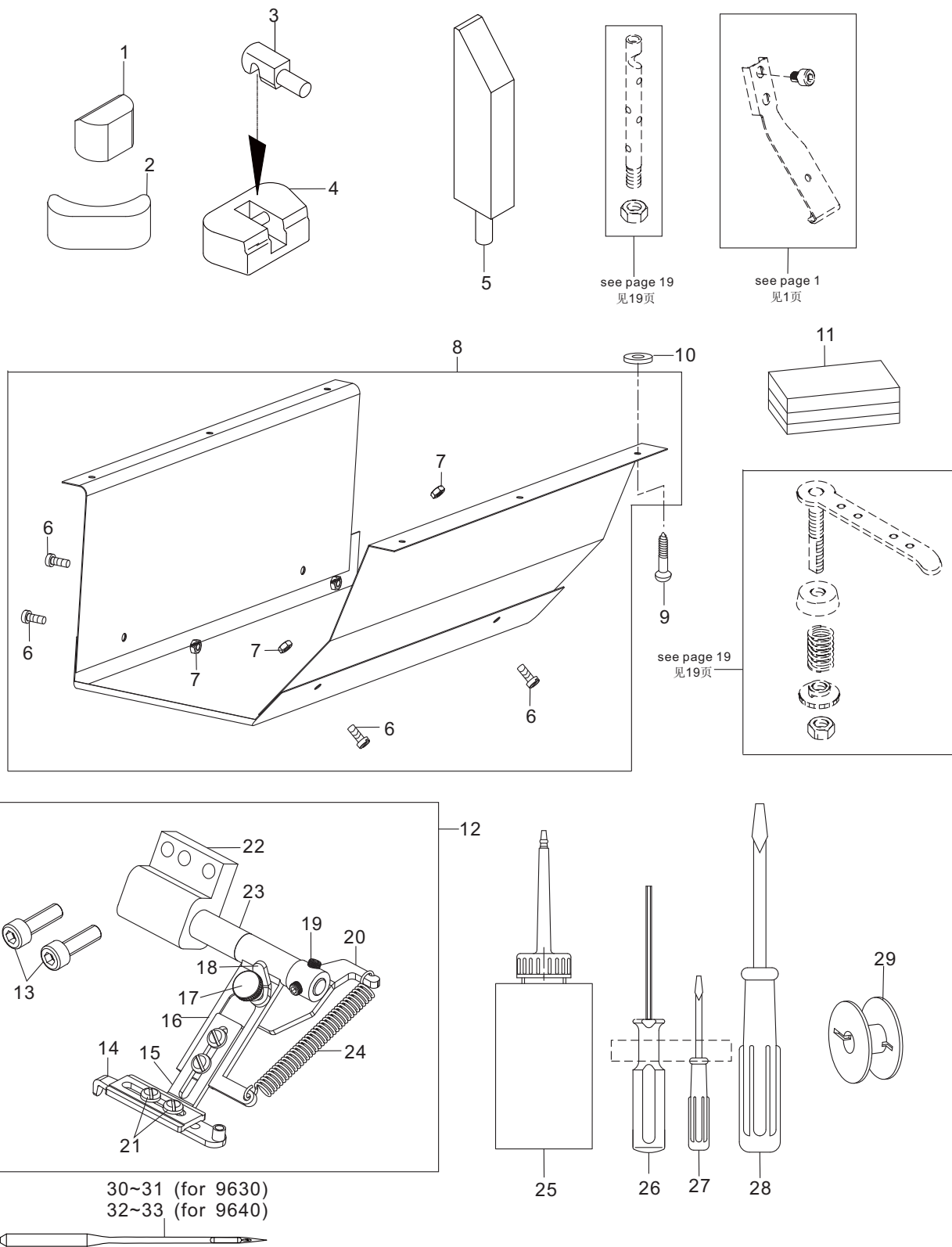

24.附件 (2) Accessories components (2)

序号 No.	件号 Part No.	名称	DESCRIPTION	数量 Qty
1	10005114	机头支座	Head support	2
2	10005248	机头座垫	Head cushion	2
3	10005374	机头铰链	head hinge	2
4	10005030	机头铰链座组件	Head hinge base assembly	2
5	10005484	木支架组件	Wood bracket assembly	1
6	10005299	螺钉 M4×5	Screw M4×5	4
7	10005297	螺母 M4	Nut M4	4
8	10056279	机头油盘	Head pan assembly	1
9	10008323	螺钉 ST4.2×20-C-H	Wood screw ST4.2×20-C-H	6
10	10005363	油盘油毡垫	Oil felt gasket	6
11	10007455	机头罩	Head cover	1
12	10041957	罗拉车靠边器	Pull device	1
13	10003164	螺钉 M5×16	Screw M5×16	2
14	10041972	靠边板组件	side plate assembly	1
15	10041959	调节板	Adjusting plate	1
16	10041961	导向板焊接件	Welding guide plate	1
17	10041958	滚花高头螺钉 M4×12	Screw M4×12	1
18	10041964	紧固扳手	Fastening wrench	1
19	10041976	螺钉 M6×5	Screw M6×5	1
20	10041968	调整焊接件	Welding adjustment	1
21	10003065	螺钉 M4×5	Screw M4×5	4
22	10041965	安装座	Mounting seat	1
23	10041966	轴	Shaft	1
24	10041971	拉簧	Drag spring	1
25	10005356	油壶	Oil pot	1
26	10009270	内六角扳手	Inner six angle wrench	1
27	10013185	小螺丝刀	Small screwdriver	1
28	10010995	中螺丝刀	Medium screwdriver	1
29	10005461	梭心	Bobbin	3
30	10006103	机针134PCL 90/14(for 9630-M)	Needle 134PCL 90/14 (for 9630-M)	4
31	10004103	机针134PCL120/19(for 9630-H)	Needle 134PCL120/19 (for 9630-H)	(4)
32	10001375	机针134-35 90/14(for 9640-M)	Needle 134-35 90/14 (for 9640-M)	4
33	10030202	机针134-35120/19(for 9640-H)	Needle 134-35120/19 (for 9640-H)	(4)

25. 旋梭右支座 (1)

Hook post, right (1)

序号 No.	件号 Part No.	名称	DESCRIPTION	数量 Qty
1	10005378	薄料旋梭 (for -M)	Hook-thin (for -M)	1
2	10069326	厚料旋梭 (for -H)	Hook-thickness (for -H)	1
3	10055263	进口旋梭	Hook (made in japan)	1
4	10004944	板式弹簧螺钉 I	Screw	1
5	10005206	板式弹簧螺钉 II	Screw	1
6	10005488	板式弹簧	Spring plate	1
7	10005555	梭头体	Hook-top	1
8	10005066	弹簧片	Spring	1
9	10005518	梭宛	Shuttle wan	1
10	10005541	螺钉	Screw	3
11	10005203	内梭头舌-薄料 (for -M)	Shuttle' tongue (for -M)	1
12	10005308	内梭头舌-厚料 (for -H)	Shuttle' tongue (for -H)	1
13	10005452	梭壳	Bobbin case	1
14	10005184	注塞	Wick	1
15	10005353	油毡注塞	Oil felt wick	1
16	10005354	螺钉 M3×4	Screw M3×4	1
17	10005106	螺钉 M2.6×4	M2.6×4	1
18	10005315	护针板	Needle protected plate	1
19	10056815	螺钉 M5×13	Screw M5×20	1
20	10004937	O形圈	O ring	1
21	10005360	旋梭端盖	Hook lid	1
22	10005245	旋梭传动芯轴	Hook transmission mandrel	1
23	10005346	小端面轴承	End bearing	1
24	10007368	滚针轴承	Needle bearing	(2)
25	10007376	滚针轴承	Needle bearing	(2)
26	10007199	滚针轴承	Needle bearing	2
27	10007198	滚针轴承	Needle bearing	(2)
28	10007197	滚针轴承	Needle bearing	(2)
29	10066691	旋梭轴	Hook shaft	1
30	10066237	螺钉 M4×3.3	Screw M4×3.3	1
31	10069601	动刀	Movable knife	1
32	10066696	动刀座B	Movable knife holder	1
33	10005549	螺钉 M6×5	Screw M6×5	2
34	10009654	6挡圈	Collar	1
35	10054469	8垫圈	Washer	1
36	10066692	动刀轴B	Knife shaft	1
37	10005029	28挡圈	Collar	1
38	10007200	轴承 6001ZZ	Bearing 6001ZZ	1
39	10066716	剪线曲柄组件B	Crank	1
40	10005139	螺钉 M5×12	Screw M5×12	1
41	10038303	垫圈 Φ8	Washer	3
42	10006298	传动旋梭齿轮 II 组件	The hook driving gear II components	1
43	10005358	传动旋梭齿轮 II	The hook driving gear II	1
44	10005258	螺钉 M6×0.75×5	Screw M6×0.75×5	2
45	10005549	螺钉 M6×5	Screw M6×5	2
46	10005413	8旋梭传动芯轴挡圈	Collar	1
47	10009187	螺钉 M6×8	Screw M6×8	1
48	10005260	4垫圈	Washer	2
49	10005257	偏心销	Eccentric pin	1
50	10012752	螺钉 M4×10	Screw M4×10	2
51	10005379	螺钉 M4×4.5	Screw M4×4.5	2
52	10069602	定刀	Fixed knife	1
53	10001807	螺钉 M2×2	Screw M2×2	1
54	10066700	夹线片DT	Wire clip	1
55	10066699	定刀座DT	Fixed knife holder	1
56	20025495	旋梭右支座机加DT喷漆	Hook the right bearing	1
57	10011803	螺钉 M5×6	Screw M5×6	1

26. 旋梭右支座(2) Hook post , right(2)

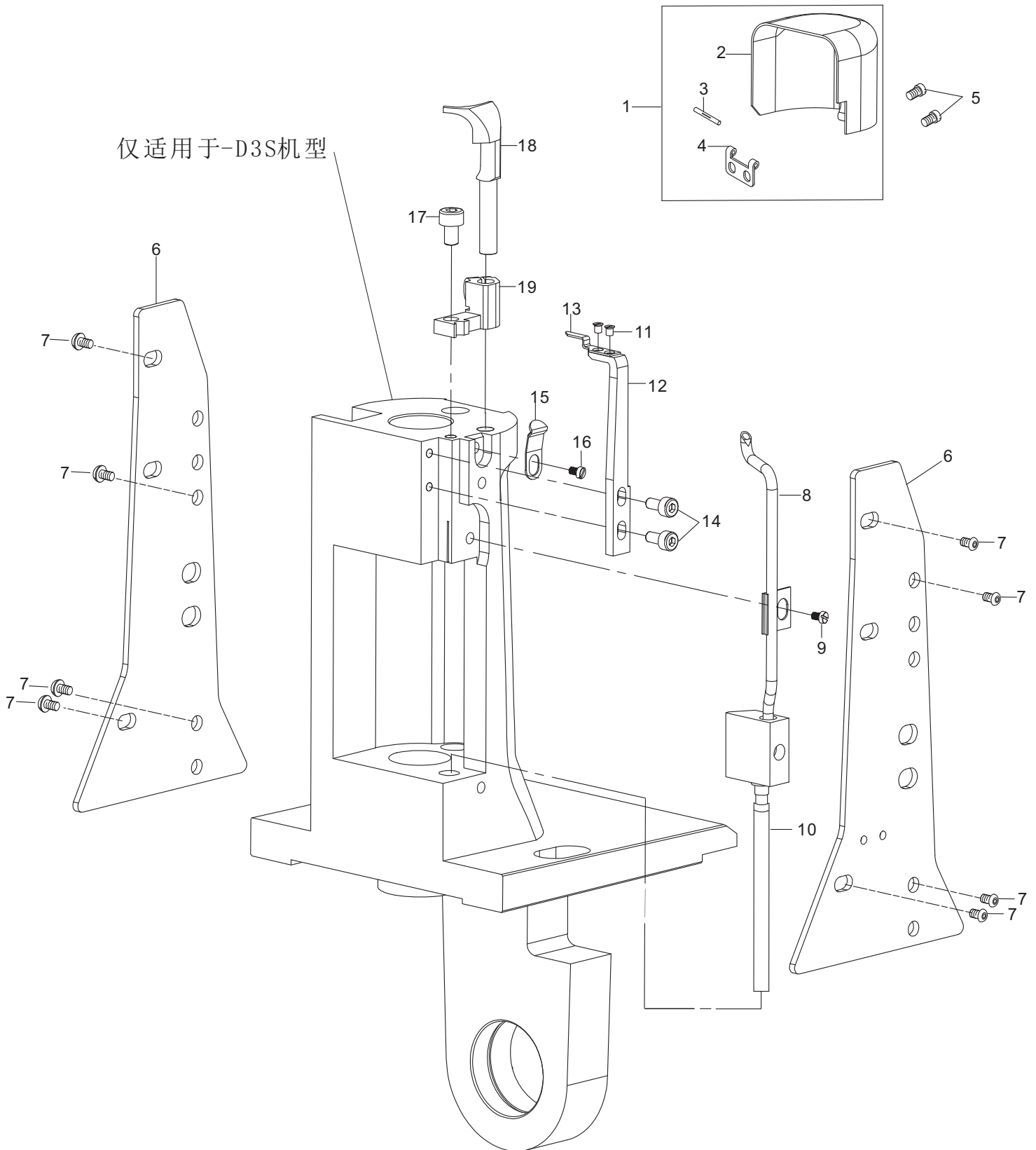

26. 旋梭右支座 (2)

Hook post, right (2)

序号 No.	件号 Part No.	名称	DESCRIPTION	数量 Qty
1	10066693	旋梭防护罩组件D	Hook shield components	1
2	10066694	旋梭防护罩D	Hook shield	1
3	10066714	销	Washer	1
4	10066695	护罩转动座D	Shield driving seat	1
5	10005186	螺钉 M4x8	Screw M4x8	2
6	20025494	侧盖板B喷漆	plate measuring	2
7	10005107	螺钉 M4x6	Screw M4x6	8
8	10066713	油量调节组件B	Rubber assy	1
9	10005076	螺钉 M4x6	Screw M4x6	1
10	10007800	油管	Oil felt	1
11	10066718	M2x2螺钉	Screw M2x2	2
12	10066701	固定板	Fixed plate	1
13	10066702	限位板	The limit board	1
14	10000909	螺钉 M3x8	Screw M3x8	2
15	10004999	弹簧板	Spring plate	1
16	10005309	螺钉 M4x6	Screw M4x6	1
17	10005405	螺钉 M4x9	Screw M3x9	1
18	10066854	旋梭定位勾DT	Positioning finger	1
19	10066704	定位勾座D	Positioning finger plate	1



浙江中捷缝纫科技有限公司
ZOJE SEWING MACHINE CO., LTD.

地址：浙江省玉环县大麦屿开发区
Add: damayu Development Zone, Yuhuanxian, Zhejiang 317604, China
国内营销中心：Domestic Business Center
Tel: 0576-87338345 87338215 Fax: 0576-87338222
国际营销中心：International Business Center
Tel: +86-576-87333222 87338299 Fax: +86-576-87332702
www.zoje.com E-mail: sales@zoje.com

